

POLLING PLACES IN DELAWARE

FINDINGS AND RECOMMENDATIONS FOR COMPLIANCE WITH THE *AMERICANS WITH DISABILITIES ACT (ADA)* AND THE *HELP AMERICA VOTE ACT*

**Prepared for:
State of Delaware
Commissioner of Elections**



Volume I
(Fire Halls, Community Centers,
Churches and Clubs)
Sussex County
December, 2005

Gray Smith's Office

Architecture & Community Development
Expert Analysis & Testimony

1219 Locust Street
Philadelphia, PA 19107

Gray Smith's Office

Architecture & Community Development
Expert Analysis & Testimony

CONTENTS

INTRODUCTION

ACKNOWLEDGEMENTS

GRAY SMITH'S OFFICE

Findings and Recommendations: Polling Places in Sussex County

Slaughter Neck Community Center
Ellendale Fire Hall
Redden Community Hall
Greenwood Fire Hall
Seaford City Hall Annex
Blades Fire Hall
Laurel Fire Hall Station 81
Harbeson Church Hall
Bridgeville Fire Hall
Lewes Fire Hall
Mid Sussex Rescue Squad Station 91
Indian River Fire Co.
Indian River Fire Hall
Dagsboro Fire Hall
Millsboro Civic Center
Millsboro Town Hall
Gumboro Fire Hall
Delmar Fire Hall
Frankford Fire Hall
Roxana Fire Hall Station 90
Roxana Sub Station #2
Millville Fire Hall
Bethany Beach Fire Hall
Fenwick Island Town Hall
Rehoboth Beach Fire Hall
Rehoboth Fire Hall (Sub-Station)

INTRODUCTION

This volume is one of three, one for each County in Delaware, documenting information obtained from surveys of 127 polling places in the state. The purpose of the effort was to identify, at each site, the physical conditions that create architectural barriers to disabled persons, which might prevent them from voting, or would otherwise be hazardous to disabled persons. The basis for the analysis was the federal *Help America Vote Act* and the *Americans with Disabilities Act (ADA)*.

It was noted that the staffs of the Departments of Elections for Kent, New Castle and Sussex Counties had made great strides toward improving polling place accessibility before this study was assigned. Those efforts included extensive mitigations of a temporary nature, including detailed site surveys and drawings, portable signs, and personal assistance. The Departments' staffs were frequently called upon to review and advise on changes at polling places that might affect accessibility.

Report format: An individual report has been prepared for each polling place site and building. A corrective action is recommended for each defective condition, so as permanently to provide *ADA* compliance. The reports are intentionally formatted in 3-ring binders, and also electronically for computer review. Each site report can be shared with the stakeholders for that site.

Implementation: There are several ways to undertake the physical work outlined to improve conditions for accessibility. Virtually every activity involves some design work and construction. Based on the sources of funds and the applicable procurement policies, there are several methods to consider:

Gray Smith's Office

Architecture & Community Development
Expert Analysis & Testimony

- Require each polling place owner to implement the corrections, either with their own funds or reimbursed with public funds.
- Engage state or county governmental agency(s) to contract for architectural design and construction at all or most of the sites, perhaps in multiples.
- Undertake a combination of the 2, based on local preferences.

In any event, there are several unavoidable steps in the process of performing the corrections at a polling place:

- Architectural and/or engineering drawings detailing the work to be performed.
- Some or all of: a Building Permit; Department of Streets Permit; Electrical Permit.
- A construction contract for the work, with all of the standard safeguards.
- Inspections of the work by the architect and/or engineer, and the local Codes Official.
- Verification of correct completion relayed to the Election Commission, and the County Departments of Elections.

Regulatory requirements: It was observed during the course of the surveys that many of the non-accessibility features were also in violation of other regulatory requirements expected of the facilities, even if it were not a polling place. Most of the defects were not in compliance with the *Americans with Disabilities Act Accessibility Guidelines (ADAAG)*, the *Fair Housing Act Fair Housing Accessibility Guidelines*, state accessibility regulations, and/or local Building Codes. It is strongly recommended that the owners of each facility visited consult with architects to assure that full regulatory compliance is pursued when the work is designed.

Gray Smith's Office

Architecture & Community Development
Expert Analysis & Testimony

Details to consider: During implementation of the recommendations, it will be important for those undertaking the design and construction to consider the following:

- **Parking availability:** On election day, it was suggested that at least 2 accessible parking spaces be made available – all day – for disabled voters. At some locations, this effort might exclude daily users who might otherwise be using the parking spaces. In some instances, it was clear that fewer accessible spaces were provided at the site than were required by the various regulations noted above. Many locations had no van-accessible spaces, although required by regulations to do so. The County Departments of Elections compensated in some cases by temporarily identifying and reserving regular parking spaces for disabled voters on election day. It will therefore be necessary at each site to determine the full total of accessible and van-accessible spaces required by regulation – in most cases more than 2 spaces alone. Once achieved, the Departments of Elections can simply identify and preserve, with portable signage, 2 permanently accessible parking spaces for election day in cooperation with the property owner.
- **Parking signs:** Upright signs are required for every permanent accessible parking space. Signage used for identifying accessible parking spaces were observed at the polling place with many different messages. Several were in accordance with the Delaware Department of Transportation regulations (see below). Many were not. It is recommended that parking signs at each site be replaced with the correctly worded sign, if not currently correct. Signs should be wall-mounted if a wall is available, or on a permanent upright sign post, at 5 feet high.

Gray Smith's Office

Architecture & Community Development
Expert Analysis & Testimony



Source: DE Department of Transportation

A supplemental sign for van-accessible parking spaces: VAN-ACCESSIBLE – can be placed below the official sign shown above.

- **“handicapped”**: Use of the term “handicapped” has become archaic, in that the disabled community has determined that the term does not accurately represent the character of physically disabled persons. It has been demonstrated that the international blue wheelchair symbol (as seen on the sign above) is now universally recognized for its meaning. As such, it is recommended that, where “handicapped” now appears on any signs at polling places, it be replaced with the symbol. Should the written word be necessary in some cases, “disabled” and “accessible” are acceptable terms.
- **Surface painting**: General parking surface striping is usually undertaken with white or yellow paint. Surface paint used for accessible parking spaces, side access aisles, accessible routes and crosswalks specifically for disabled persons, and accessibility symbols are recommended to be medium to light blue, depending on the darkness of the paved surface. Periodic repainting is also necessary due to wear.

Gray Smith's Office

Architecture & Community Development
Expert Analysis & Testimony

- **Snow and ice:** As most polling places, the potential for surface accumulation of ice and snow is high during inclement weather. Arrangements should be made to assure availability of melting chemicals before and during election day.

Finally, it is suggested that the corrective work performed at each location be documented with digital cameras when completed and transmitted to the appropriate Department of Elections and to the Commissioner of Elections. This activity, when recorded, will verify compliance. Such documentation can be made a requirement of a construction contract.

Gray Smith's Office

Architecture & Community Development
Expert Analysis & Testimony

ACKNOWLEDGEMENTS

The efforts undertaken to produce this study were made possible through the leadership and funding from Delaware's Commissioner of Elections, Frank B. Calio and his staff. Assisting in the 11, day-long trips to polling places were Cara Hartsky (Department of Elections for New Castle County), Barbara Lippincott (Department of Elections for New Castle County), Gary Hilderband (Department of Elections for Kent County) and Wayne Osborn (Department of Elections for Sussex County), who also made sure no one got lost. A well-drawn set of diagrams on temporary election day signage and parking locations at many of the sites was very helpful.

Encouragement was received from the Delaware Disabilities Law Program, Laura J. Waterland, Esquire.

Finally, Kimberly Latona, Office Manager and Gray Smith's Office overall computer expert, developed the intricate layouts for the survey forms and books, and the final report. They are easy to understand and follow up with productive action.

Reference was made to a number of key federal and local publications oriented toward making the polling places accessible to disabled persons. They are recommended for anyone concerned with this important goal.

1. *Americans with Disabilities Act ADA Checklist for Polling Places*, U.S. Department of Justice, Civil Rights Division, Disability Rights Section, February 2004. Copies available for download: www.ada.gov or by calling the ADA Information Line at 800-514-0301 (voice), 800-514-0383 (TTY).

Gray Smith's Office

Architecture & Community Development
Expert Analysis & Testimony

2. *Code of Federal Regulations: 28 CFR Part 36, Revised as of July 1, 1994 – Nondiscrimination on the Basis of Disability by Public Accommodations and in Commercial Facilities, which includes the Americans with Disabilities Act Accessibility Guidelines (ADAAG).*
3. *ADAAG Manual: a guide to the Americans with Disabilities Act Accessibility Guidelines*, U.S. Architectural and Transportation Barrier Compliance Board, July 1998.
4. *State of Delaware – STATE PLAN – Help America Vote Act*, September 15, 2003, Frank B. Calio, Commissioner of Elections.
5. Brochure: *Voting is Easy in Delaware!*, State of Delaware Commission of Elections.
6. *Disabilities Law Program Primary Accessibility Survey*, Community Legal Aid Society, Inc., Wilmington, DE, May 5, 2004.
7. “The Face of Accessibility in the Voting Process”, *Outlooks, A Newsletter from the Pennsylvania Developmental Disabilities Council*, Fall 2002.
8. “Help America Vote Act: New Law Includes Provisions for Access”, *ADA & IT in focus*, a publication of the ADA & IT Information Center for the Mid-Atlantic Region, Fall 2003.

With appreciation to all that helped:

Gray Smith AIA AICP

Gray Smith's Office

Architecture & Community Development
Expert Analysis & Testimony

GRAY SMITH AIA AICP

Gray Smith AIA AICP, is the owner of **Gray Smith's Office**, an architectural and urban planning consulting practice. The firm has undertaken many construction projects with an equal emphasis on rehabilitation, historic preservation and new construction, including complex housing, commercial and institutional projects. For governments and non-profit organizations, the firm completed numerous inner-city and downtown planning studies. **Gray Smith's Office** also provides services in forensic analysis and testimony on premises liability, construction litigation, accessibility for disabled persons, planning and zoning, and related disputes.

Mr. Smith was a founding board member of the **Preservation Coalition of Greater Philadelphia**. He was President of the **Philadelphia Chapter of the American Institute of Architects (AIA)** in 1982 and Chair of its Urban Design Committee. He is a member of the **American Institute of Certified Planners (AICP)**, **International Code Council**, and the **National Fire Prevention Association (NFPA)**. He is a shareholder in the **Atheneum** of Philadelphia.

Gray Smith has served as board member of the **Citizens Coalition for Energy Efficiency (C2E2)**, and the **Housing Consortium for Disabled Individuals (HCDI)**. He was a member of the **Philadelphia Bar Association's Investigative Division of the Commission on Judicial Selection and Retention**, an arbitration panelist for the **American Arbitration Association (AAA)** Construction Division, and is a technical advisor to the **SeniorLaw Center**. He has been Chairperson of the Zoning and Code Enforcement Committees of the **South Street Neighborhood Association (SSNA)**, and the **Bella Vista Civic Association**, and Chair of the **SSNA** Liquor Control Committee. Mr. Smith is a past **SSNA** President.

In Philadelphia, Gray Smith was appointed by Mayor Wilson Goode to the **Mayor's Task Force on the Schuylkill Falls Housing Project**, and served on Councilman Ed Schwartz's **Task Force on Neighborhood Resources** and on the **Managing Director's South Street Task Force**. He participated in the **Adaptable Housing Standards Committee** in amending the Philadelphia Building Codes, and was a consultant to the **Fire Safety Committee** of the **Boarding Home Residents Task Force** regarding City Fire Code revisions. The firm produced the **Stair Injury Prevention Manual** for the Philadelphia Injury Prevention Program of the City Health Department. Mr. Smith is a member of the **Barrier-Free Design Committee** of the **Mayor's Commission on Persons with Disabilities**.

In 2003, Mr. Smith received the Regional Award for accessibility advocacy from the **Inglis Foundation of Philadelphia**. He received the 1995 Preservation Achievement Award from the **Philadelphia Historic Preservation Corporation**.

In 1998, 1999 and 2000, Mr. Smith was appointed by the **International Code Council** to serve on the **International Zoning Code Committee**, and the **International Property Maintenance Code Development Committee**, in the annual code change review process. In April 2005, he conducted a seminar on *The Construction Code System in Philadelphia* for the **Lorman Education Services** continuing education program. He serves on the Advisory Committee for the **ADA & IT Information Center for the Mid-Atlantic Region**. He is a member of the **Inclusive Communities Working Group** of the **Housing Alliance of PA**.

Mr. Smith has a Masters degree from **Tulane University School of Architecture** (1965) in New Orleans. He was a **Loeb Fellow in Advanced Environmental Studies** at the **Harvard Graduate School of Design** (1973-74). He is licensed to practice in Pennsylvania, New Jersey and Delaware.

Gray Smith's Office

Architecture & Community Development
Expert Analysis & Testimony

Mr. Smith authored a column in the *Philadelphia City Paper* on "Endangered Buildings and Places". He has presented many lectures and invited papers, and has been a contributor to the *Philadelphia Daily News* and *Philadelphia Inquirer* newspapers.

11.05

Polling Place Accessibility Surveys

Sussex County



Gray Smith's Office

Architecture & Community Development
Expert Analysis & Testimony

DELAWARE COMMISSIONER OF ELECTIONS POLLING PLACE ACCESSIBILITY RECOMMENDATIONS	
Name of Polling Place: Slaughter Neck Community Center	
County: Sussex	
Address: 22942 Slaughter Neck Road, Lincoln	
Contact Person(s) Assisting Survey: Wayne Osborn	
Voting Area: Community Center: Dining Room	

FINDINGS AND RECOMMENDATIONS BASED ON ON-SITE SURVEY AND ADA REQUIREMENTS	
Survey Performed by: Gray Smith AIA AICP Survey Date: June 14, 2005	
<p>1. Entrance door: Entrance door requires a push pressure of 9 pounds to open.</p> <p>Recommendation: Adjust or replace automatic door closer to assure maximum 5 pounds push pressure.</p>	

Gray Smith's Office

Architecture & Community Development
Expert Analysis & Testimony

DELAWARE COMMISSIONER OF ELECTIONS POLLING PLACE ACCESSIBILITY RECOMMENDATIONS	
Name of Polling Place: Ellendale Fire Hall	County: Sussex
Address: 302 Main Street, Ellendale	
Contact Person(s) Assisting Survey: Wayne Osborn	
Voting Area: Volunteer Fire Hall: "Main Hall"	

FINDINGS AND RECOMMENDATIONS BASED ON ON-SITE SURVEY AND ADA REQUIREMENTS
Survey Performed by: Gray Smith AIA AICP
Survey Date: June 14, 2005

Note: Entry was not available at this facility during the visit.

- Parking:** Accessible parking is provided; however there is no van-accessible space and no upright signs.

Recommendation: Reconfigure and add van-accessible space and side access aisle in accordance with drawing below. Add upright signs at 5 feet high and with "van-accessible" sign. Move wheelstops further into parking space so as to prevent vehicle contact with signs.

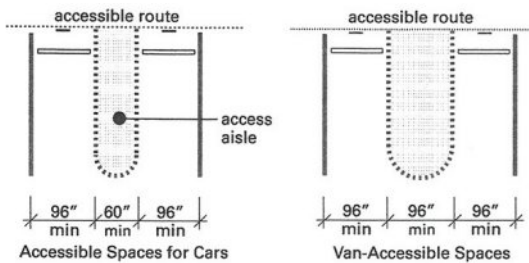

Gray Smith's Office

Architecture & Community Development
Expert Analysis & Testimony

Name of Polling Place: Ellendale Fire Hall **County:** Sussex

FINDINGS AND RECOMMENDATIONS BASED ON ON-SITE SURVEY AND ADA REQUIREMENTS

Survey Performed by: Gray Smith AIA AICP

Survey Date: June 14, 2005

- 2. Entrance door:** An irregular cracked area at the threshold caused a raised edge higher than ½ inch.

Recommendation: Cut out and patch concrete with epoxy concrete for a beveled, even transition.



Gray Smith's Office

Architecture & Community Development
Expert Analysis & Testimony

DELAWARE COMMISSIONER OF ELECTIONS POLLING PLACE ACCESSIBILITY RECOMMENDATIONS	
Name of Polling Place: Redden Community Hall	County: Sussex
Address: 18192 Redden Road, Georgetown	
Contact Person(s) Assisting Survey: Cara Hartsky	
Voting Area: Community Center: Community Room	

FINDINGS AND RECOMMENDATIONS BASED ON ON-SITE SURVEY AND ADA REQUIREMENTS
Survey Performed by: Gray Smith AIA AICP
Survey Date: June 14, 2005

Note: Entry to the facility was not available during the visit.

- 1. Parking:** Parking, grass and road blended together such that there was no designated on-site parking.

Recommendation: Pave a portion of the site and designate 2 parking spaces as accessible, one as van-accessible, with side access aisles as indicated in the drawing below. Include upright signs at 5 feet high and one "van-accessible" sign.

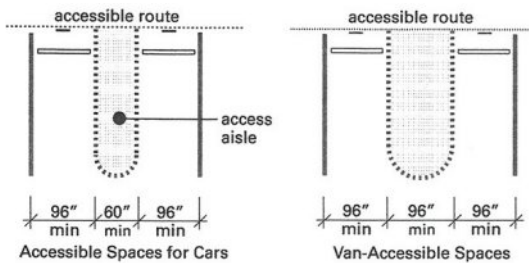

Gray Smith's Office

Architecture & Community Development
Expert Analysis & Testimony

Name of Polling Place: Redden Community Hall County: Sussex

FINDINGS AND RECOMMENDATIONS BASED ON ON-SITE SURVEY AND ADA REQUIREMENTS

Survey Performed by: Gray Smith AIA AICP

Survey Date: June 14, 2005

2. **Route to entrance:** The route to the bottom of the entrance ramp was grass and gravel.

Recommendation: Install a 48 inches wide concrete walkway from the accessible parking spaces (see above) to the bottom of the ramp.

3. **Entrance ramp:** The entrance ramp had handrails; however, they did not extend to the bottom of, or beyond the bottom of, the ramp by 12 inches. There was a raised edge at the bottom of the ramp that was higher than 1/2 inch.

Recommendation: Add extensions to the bottoms of the handrails to 12 inches beyond the end of the ramp surface, as indicated in the drawing below. Assure that the new concrete walkway (see above) levels with the bottom of the ramp surface.

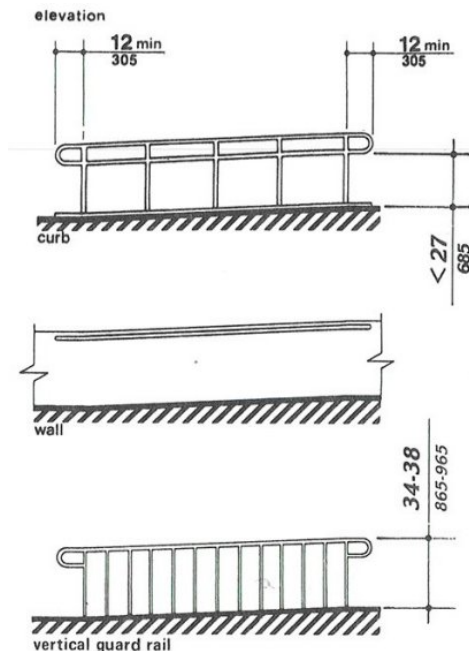

Gray Smith's Office

Architecture & Community Development
Expert Analysis & Testimony

Name of Polling Place: Redden Community Hall **County:** Sussex

FINDINGS AND RECOMMENDATIONS BASED ON ON-SITE SURVEY AND ADA REQUIREMENTS

Survey Performed by: Gray Smith AIA AICP

Survey Date: June 14, 2005

- 4. Entrance doors:** The double entrance doors were each 31 inches wide when closed, such that when open 32 inches clear would not be possible. There were doorknobs, and the threshold was 1 ¾ inches high. The screen doors were an additional obstacle.

Recommendation: Replace the doorknobs with lever handles. Replace the threshold with a wider, low-profile, aluminum threshold. Assure that, on election day, Personnel is available to open both doors and screen doors for wheelchairs.



Gray Smith's Office

Architecture & Community Development
Expert Analysis & Testimony

DELAWARE COMMISSIONER OF ELECTIONS POLLING PLACE ACCESSIBILITY RECOMMENDATIONS	
Name of Polling Place: Greenwood Fire Hall	County: Sussex
Address: 12611 Sussex Highway, Greenwood	
Contact Person(s) Assisting Survey: Wayne Osborn	
Voting Area: Volunteer Fire Hall: Community Hall	

FINDINGS AND RECOMMENDATIONS BASED ON ON-SITE SURVEY AND ADA REQUIREMENTS
Survey Performed by: Gray Smith AIA AICP
Survey Date: June 14, 2005

- 1. Parking:** Accessible parking was provided; however, there were no side access aisles and the surface paint was wearing away.

Recommendation: Reconfigure and repaint accessible spaces to provide side access aisles and a van-accessible space as indicated in the following drawing. Maintain van-accessible space and signs. Coordinate with curb ramp position.

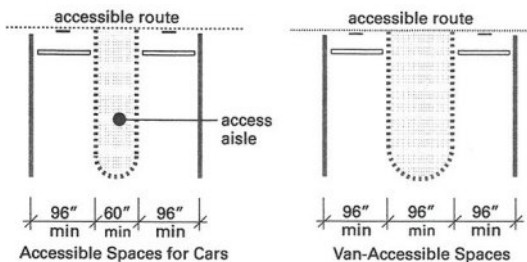

Gray Smith's Office

Architecture & Community Development
Expert Analysis & Testimony

Name of Polling Place: Greenwood Fire Hall **County:** Sussex

FINDINGS AND RECOMMENDATIONS BASED ON ON-SITE SURVEY AND ADA REQUIREMENTS

Survey Performed by: Gray Smith AIA AICP

Survey Date: June 14, 2005

- 2. Route to entrance:** Concrete walkway to entrance is 36 inches wide and has shrubbery growing over one-third of the width.

Recommendation: Cut back shrubbery before election day. In the alternative, add 18 inches of concrete paving to walkway.

- 3. Entrance door:** Entrance door requires 12 pounds of push pressure to open.

Recommendation: Adjust or replace automatic door closer to assure maximum of 5 pounds push pressure.



Gray Smith's Office

Architecture & Community Development
Expert Analysis & Testimony

DELAWARE COMMISSIONER OF ELECTIONS POLLING PLACE ACCESSIBILITY RECOMMENDATIONS	
Name of Polling Place: Seaford City Hall Annex	County: Sussex
Address: 414 High Street, Seaford	
Contact Person(s) Assisting Survey: Cara Hartsky	
Voting Area: City Hall	

FINDINGS AND RECOMMENDATIONS BASED ON ON-SITE SURVEY AND ADA REQUIREMENTS

Survey Performed by: Gray Smith AIA AICP

Survey Date: June 14, 2005

- 1. Parking:** Accessible parking spaces are provided; however, none were van-accessible.

Recommendation: Reconfigure the parking to include one van-accessible parking space, as indicated in the drawing below. Add a "van-accessible" sign.

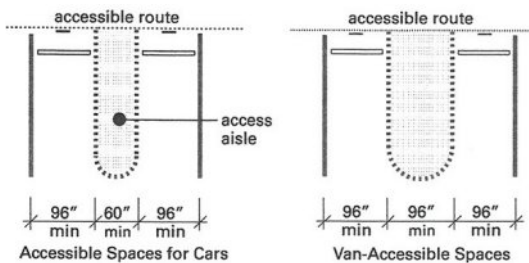

Gray Smith's Office

Architecture & Community Development
Expert Analysis & Testimony

DELAWARE COMMISSIONER OF ELECTIONS POLLING PLACE ACCESSIBILITY RECOMMENDATIONS	
Name of Polling Place: Blades Fire Hall	County: Sussex
Address: 200 E. 5 th Street, Seaford	
Contact Person(s) Assisting Survey: Wayne Osborn	
Voting Area: Volunteer Fire Hall: Community Room	

FINDINGS AND RECOMMENDATIONS BASED ON ON-SITE SURVEY AND ADA REQUIREMENTS

Survey Performed by: Gray Smith AIA AICP
Survey Date: June 14, 2005

1. Parking: Accessible parking was provided; however: there was no surface painting; there were no side access aisles; there was no van-accessible space. The surface had much loose gravel.

Recommendation: Repave and surface paint the accessible parking area. Include side access aisles and a van-accessible space in accordance with the drawing below. Replace the wall signs without "handicap" wording. Add "van-accessible" sign.

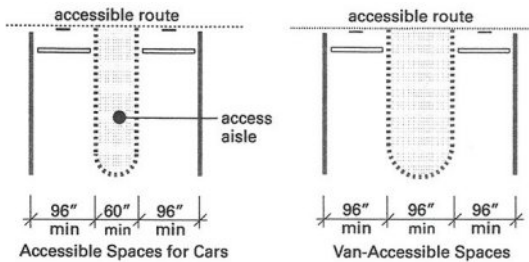

Gray Smith's Office

Architecture & Community Development
Expert Analysis & Testimony

Name of Polling Place: Blades Fire Hall **County:** Sussex

FINDINGS AND RECOMMENDATIONS BASED ON ON-SITE SURVEY AND ADA REQUIREMENTS

Survey Performed by: Gray Smith AIA AICP

Survey Date: June 14, 2005

- 2. Entrance doors:** The entrance doors require push pressures of 8 to 15 pounds to open.

Recommendation: Adjust or replace automatic door closers to assure a maximum of 5 pounds push pressure.



Gray Smith's Office

Architecture & Community Development
Expert Analysis & Testimony

DELAWARE COMMISSIONER OF ELECTIONS POLLING PLACE ACCESSIBILITY RECOMMENDATIONS	
Name of Polling Place: Laurel Fire Hall Station 81	County: Sussex
Address: 205 W. 10 th Street, Laurel	
Contact Person(s) Assisting Survey: Cara Hartsky	
Voting Area: Volunteer Fire Hall: Engine Room	

FINDINGS AND RECOMMENDATIONS BASED ON ON-SITE SURVEY AND ADA REQUIREMENTS

Survey Performed by: Gray Smith AIA AICP

Survey Date: June 14, 2005

- 1. Parking:** The van-accessible parking spaces do not have "van-accessible" signs.

Recommendation: Add "van-accessible" signs.

- 2. Entrance doors:** The entrance doors require a push pressure of 10 pounds to open.

Recommendation: Adjust or replace automatic door closer to assure a maximum of 5 pounds push pressure.

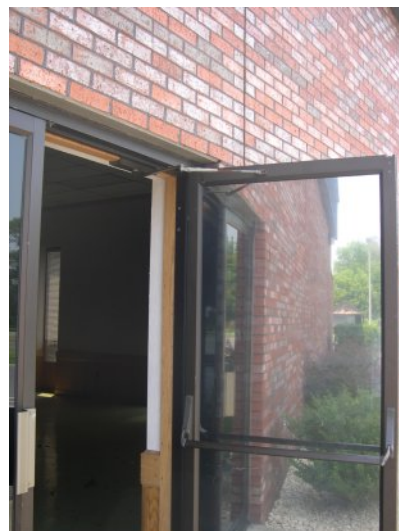

Gray Smith's Office

Architecture & Community Development
Expert Analysis & Testimony

DELAWARE COMMISSIONER OF ELECTIONS POLLING PLACE ACCESSIBILITY RECOMMENDATIONS	
Name of Polling Place: Harbeson Church Hall	County: Sussex
Address: 18636 Harbeson Road, Harbeson	
Contact Person(s) Assisting Survey: Wayne Osborn	
Voting Area: Church	

FINDINGS AND RECOMMENDATIONS BASED ON ON-SITE SURVEY AND ADA REQUIREMENTS

Survey Performed by: Gray Smith AIA AICP
Survey Date: June 14, 2005

- Parking:** There is no designated accessible parking on-site. During election day, temporary parking is set-up on a side driveway on-site.

Recommendation: Pave and surface paint 2 accessible parking spaces on-site adjacent to the side walkway. Include side access aisle and a van-accessible space as indicated in the drawing below. Provide upright signs at 5 feet high with one "van-accessible" sign.

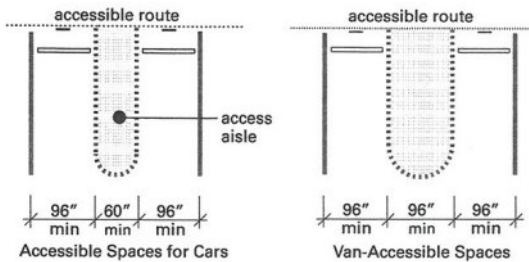

Gray Smith's Office

Architecture & Community Development
Expert Analysis & Testimony

Name of Polling Place: Harbeson Church Hall **County:** Sussex
FINDINGS AND RECOMMENDATIONS BASED ON ON-SITE SURVEY AND ADA REQUIREMENTS
Survey Performed by: Gray Smith AIA AICP
Survey Date: June 14, 2005

2. Entry ramp: The wood entry ramp has wide handrails that are not graspable. The handrails do not extend 12 inches beyond the bottom surface of the ramp.

Recommendation: Add supplementary round pipe handrails at 34 inches high and extending 12 inches beyond the top and bottom of the ramp. See drawing below.

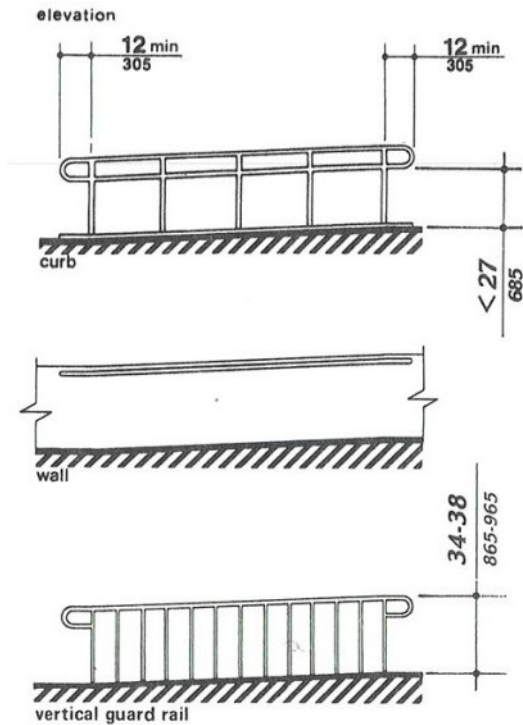

Gray Smith's Office

Architecture & Community Development
Expert Analysis & Testimony

Name of Polling Place: Harbeson Church Hall **County:** Sussex

FINDINGS AND RECOMMENDATIONS BASED ON ON-SITE SURVEY AND ADA REQUIREMENTS

Survey Performed by: Gray Smith AIA AICP

Survey Date: June 14, 2005

- 3. Entrance door:** The entrance door had doorknobs. The threshold was crooked and was raised $\frac{3}{4}$ inch.

Recommendation: Replace doorknobs with lever handles and threshold with wider, beveled, low-profile, aluminum threshold.

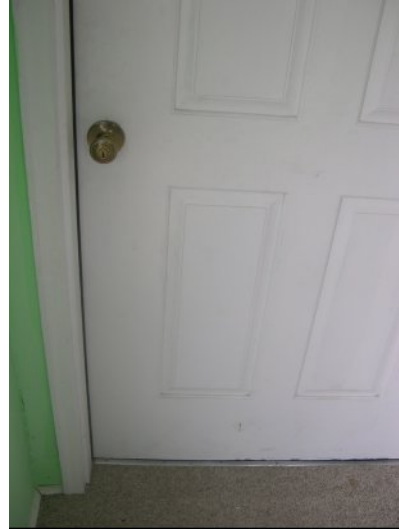

Gray Smith's Office

Architecture & Community Development
Expert Analysis & Testimony

DELAWARE COMMISSIONER OF ELECTIONS POLLING PLACE ACCESSIBILITY RECOMMENDATIONS	
Name of Polling Place: Bridgeville Fire Hall	County: Sussex
Address: 315 Market Street, Ellendale	
Contact Person(s) Assisting Survey: Wayne Osborn	
Voting Area: Fire Hall	

FINDINGS AND RECOMMENDATIONS BASED ON ON-SITE SURVEY AND ADA REQUIREMENTS

Survey Performed by: Gray Smith AIA AICP

Survey Date: June 14, 2005

- Parking:** Although the parking lot was large, there were no designated accessible parking spaces. There were no designated accessible parking spaces on the street next to the polling place entrance.

Recommendation: Locate and surface paint accessible parking spaces near to the building entrances. Include side access aisles, van-accessible space(s) in accordance with the following drawing. Include upright signs at 5 feet high and "van-accessible" sign(s).

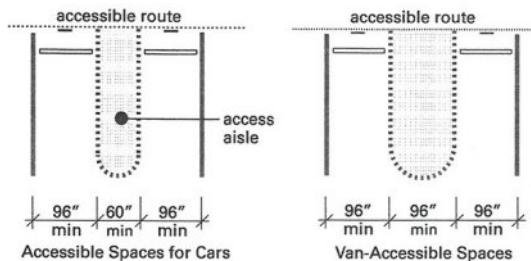

Gray Smith's Office

Architecture & Community Development
Expert Analysis & Testimony

Name of Polling Place: Bridgeville Fire Hall **County:** Sussex
FINDINGS AND RECOMMENDATIONS BASED ON ON-SITE SURVEY AND ADA REQUIREMENTS
Survey Performed by: Gray Smith AIA AICP
Survey Date: June 14, 2005

2. Entrance door: The entrance door required 10 pounds of push pressure to open.

Recommendation: Adjust or place automatic door closer to assure maximum 5 pounds push pressure.



Gray Smith's Office

Architecture & Community Development
Expert Analysis & Testimony

DELAWARE COMMISSIONER OF ELECTIONS POLLING PLACE ACCESSIBILITY RECOMMENDATIONS	
Name of Polling Place: Lewes Fire Hall	
County: Sussex	
Address: 347 Savannah Road, Lewes	
Contact Person(s) Assisting Survey: Wayne Osborn	
Voting Area:	

FINDINGS AND RECOMMENDATIONS BASED ON ON-SITE SURVEY AND ADA REQUIREMENTS
Survey Performed by: Gray Smith AIA AICP
Survey Date: June 15, 2005

1. Parking: Surface paint for original accessible spaces has worn away. There are no upright signs, no van-accessible spaces and no side access aisles.

Recommendation: Designate and surface paint accessible parking spaces with van-accessible space(s) and side access aisles as indicated in the following drawing. Include upright signs at 5 feet high and "van-accessible" signs. Locate as near to the polling place entrances as possible.

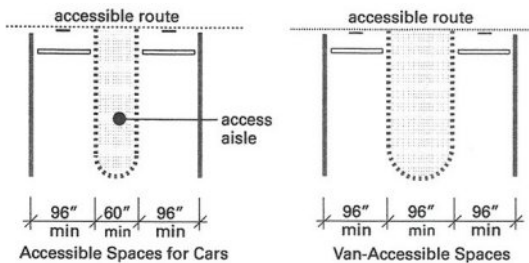

Gray Smith's Office

Architecture & Community Development
Expert Analysis & Testimony

Name of Polling Place: Lewes Fire Hall **County:** Sussex
FINDINGS AND RECOMMENDATIONS BASED ON ON-SITE SURVEY AND ADA REQUIREMENTS
Survey Performed by: Gray Smith AIA AICP
Survey Date: June 15, 2005

2. Entrance ramp: Along the alternate route to the polling place, the entrance ramp does not have handrails and does not have edge protection to prevent slipping off.

Recommendation: Install 2 handrails with extensions 12 inches top and bottom and edge protection as indicated in the drawing below.

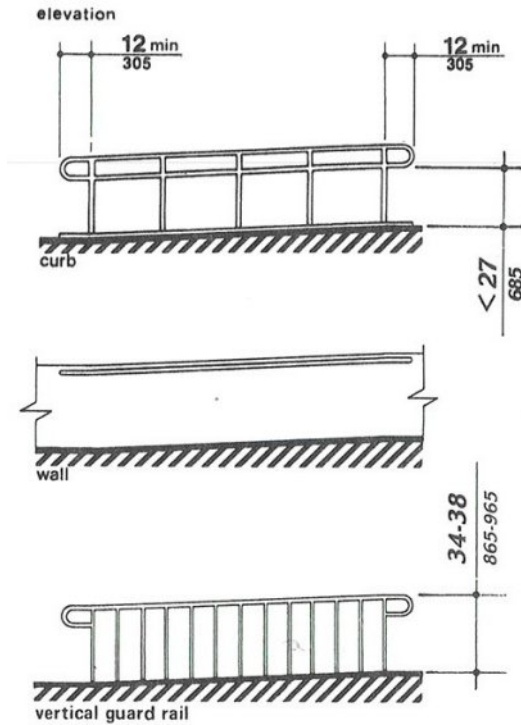

Gray Smith's Office

Architecture & Community Development
Expert Analysis & Testimony

Name of Polling Place: Lewes Fire Hall **County:** Sussex

FINDINGS AND RECOMMENDATIONS BASED ON ON-SITE SURVEY AND ADA REQUIREMENTS

Survey Performed by: Gray Smith AIA AICP

Survey Date: June 15, 2005

- 3. Entrance doors and Vestibule:** The front entrance and Vestibule doors require a push pressure of 10 to 20 pounds to open.

Recommendation: Adjust or replace automatic door closers to assure a maximum 5 pounds push pressure.



Gray Smith's Office

Architecture & Community Development
Expert Analysis & Testimony

DELAWARE COMMISSIONER OF ELECTIONS POLLING PLACE ACCESSIBILITY RECOMMENDATIONS	
Name of Polling Place: Mid Sussex Rescue Squad Station 91	
Address: 31378 Indian Mission Road, Millsboro	
Contact Person(s) Assisting Survey: Wayne Osborn	
Voting Area: EMR Garage	

FINDINGS AND RECOMMENDATIONS BASED ON ON-SITE SURVEY AND ADA REQUIREMENTS
Survey Performed by: Gray Smith AIA AICP
Survey Date: June 15, 2005

- Parking:** Accessible parking spaces are provided; however, there is no van-accessible sign.

Recommendation: Reconfigure and repaint accessible spaces to include van-accessible space and side access aisle as indicated in the drawing below. Include "van-accessible" sign.

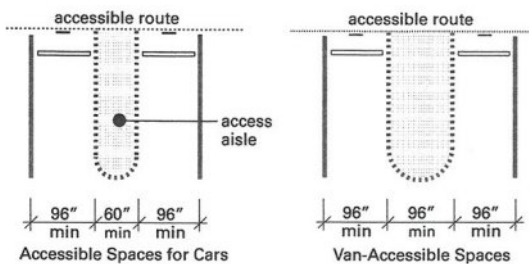

Gray Smith's Office

Architecture & Community Development
Expert Analysis & Testimony

Name of Polling Place: Mid Sussex Rescue Squad **County:** Sussex

FINDINGS AND RECOMMENDATIONS BASED ON ON-SITE SURVEY AND ADA REQUIREMENTS

Survey Performed by: Gray Smith AIA AICP

Survey Date: June 15, 2005

- 2. Entrance doors:** A pair of glass doors and separate side steel door are both used as entrance/exit doors. Each required 18 pounds of push pressure to open.

Recommendation: Adjust or replace automatic door closers to assure maximum 5 pounds push pressure.



Gray Smith's Office

Architecture & Community Development
Expert Analysis & Testimony

DELAWARE COMMISSIONER OF ELECTIONS POLLING PLACE ACCESSIBILITY RECOMMENDATIONS	
Name of Polling Place: Indian River Fire Co.	
County: Sussex	
Address: 25375 Banks Road, Millsboro	
Contact Person(s) Assisting Survey: Wayne Osborn	
Voting Area: Volunteer Fire House: Engine Room	

FINDINGS AND RECOMMENDATIONS BASED ON ON-SITE SURVEY AND ADA REQUIREMENTS	
Survey Performed by: Gray Smith AIA AICP Survey Date: June 15, 2005	
<p>Parking: Accessible parking spaces, including van-accessible parking, is provided; however, there are no upright signs.</p> <p>Recommendation: Provide upright signs at 5 feet high, including "van-accessible" signs.</p> 	

Gray Smith's Office

Architecture & Community Development
Expert Analysis & Testimony

DELAWARE COMMISSIONER OF ELECTIONS POLLING PLACE ACCESSIBILITY RECOMMENDATIONS	
Name of Polling Place: Indian River Fire Hall	County: Sussex
Address: 32628 Oak Orchard Road, Millsboro	
Contact Person(s) Assisting Survey: Wayne Osborn	
Voting Area: Volunteer Fire Hall	

FINDINGS AND RECOMMENDATIONS BASED ON ON-SITE SURVEY AND ADA REQUIREMENTS

Survey Performed by: Gray Smith AIA AICP

Survey Date: June 15, 2005

Note: Entry was not available to this facility during the visit.

- 1. Parking:** Accessible parking spaces were provided, including van accessible spaces. There were no upright signs.

Recommendation: Provide wall-mounted signs, including "van-accessible" sign, up 5 feet high.



Gray Smith's Office

Architecture & Community Development
Expert Analysis & Testimony

Name of Polling Place: Indian River Fire Hall **County:** Sussex

FINDINGS AND RECOMMENDATIONS BASED ON ON-SITE SURVEY AND ADA REQUIREMENTS

Survey Performed by: Gray Smith AIA AICP

Survey Date: June 15, 2005

- 2. Entrance doors:** There were several exterior doors into the Engine Room. One had a threshold that was higher than ½ inch. If that door is used on election day, replace the threshold with a wider, beveled, low-profile, aluminum threshold.



Gray Smith's Office

Architecture & Community Development
Expert Analysis & Testimony

DELAWARE COMMISSIONER OF ELECTIONS POLLING PLACE ACCESSIBILITY RECOMMENDATIONS	
Name of Polling Place: Dagsboro Fire Hall	County: Sussex
Address: 200 Waples Street, Dagsboro	
Contact Person(s) Assisting Survey: Wayne Osborn	
Voting Area: Volunteer Fire Hall: Community Room	

FINDINGS AND RECOMMENDATIONS BASED ON ON-SITE SURVEY AND ADA REQUIREMENTS

Survey Performed by: Gray Smith AIA AICP
Survey Date: June 15, 2005

1. **Parking:** The large paved parking areas were not striped and there were no designated accessible parking spaces.

Recommendation: At front of building designate and surface paint accessible parking spaces with side access aisles and one van-accessible space as indicated in the drawing below. Install wall-mounted signs and a "van-accessible" sign at 5 feet high.

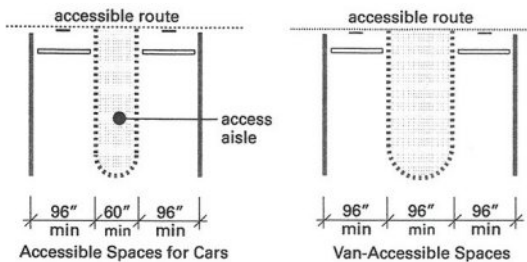

Gray Smith's Office

Architecture & Community Development
Expert Analysis & Testimony

Name of Polling Place: Dagsboro Fire Hall **County:** Sussex

FINDINGS AND RECOMMENDATIONS BASED ON ON-SITE SURVEY AND ADA REQUIREMENTS

Survey Performed by: Gray Smith AIA AICP

Survey Date: June 15, 2005

- 2. Entrance door:** The entrance door required a push pressure of 10 pounds to open. The threshold had a ½ inch vertical edge.

Recommendation: Adjust or replace automatic door closer to assure maximum 5 pounds push pressure. Replace threshold with wider, beveled, low-profile, aluminum threshold.

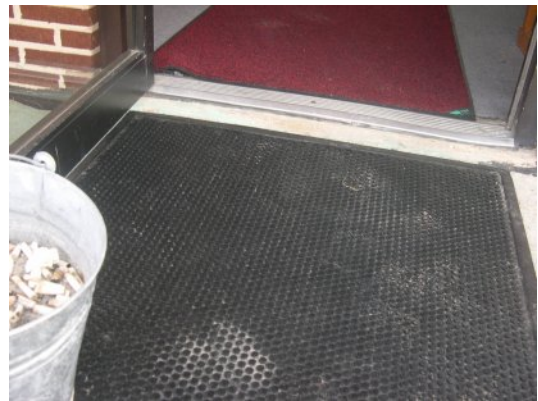

Gray Smith's Office

Architecture & Community Development
Expert Analysis & Testimony

DELAWARE COMMISSIONER OF ELECTIONS POLLING PLACE ACCESSIBILITY RECOMMENDATIONS	
Name of Polling Place: Millsboro Civic Center	
County: Sussex	
Address: 322 Wilson Highway, Millsboro	
Contact Person(s) Assisting Survey: Cara Hartsky	
Voting Area: Civic Center	

FINDINGS AND RECOMMENDATIONS BASED ON ON-SITE SURVEY AND ADA REQUIREMENTS
Survey Performed by: Gray Smith AIA AICP
Survey Date: June 15, 2005

Note: This building contains 2 polling places: Civic Center; Town Hall – each with its own entrance.)

- Parking:** Nine accessible parking spaces were provided; however, no van-accessible space was provided. The surface paint was wearing away.

Recommendation: Provide one van-accessible space with a “van-accessible” sign. See drawing below. Repaint surface.

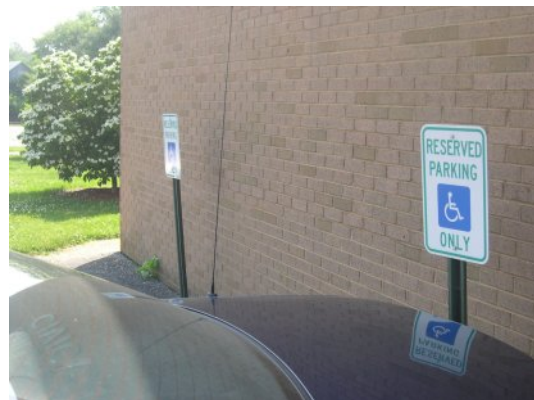
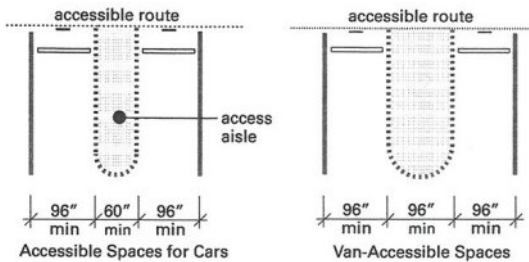

Gray Smith's Office

Architecture & Community Development
Expert Analysis & Testimony

Name of Polling Place: Millsboro Civic Center **County:** Sussex

FINDINGS AND RECOMMENDATIONS BASED ON ON-SITE SURVEY AND ADA REQUIREMENTS

Survey Performed by: Gray Smith AIA AICP

Survey Date: June 15, 2005

- 2. Entrance door:** The entrance door required 15 pounds of push pressure to open.

Recommendation: Adjust or replace automatic door closer to assure maximum 5 pounds push pressure.



Gray Smith's Office

Architecture & Community Development
Expert Analysis & Testimony

DELAWARE COMMISSIONER OF ELECTIONS POLLING PLACE ACCESSIBILITY RECOMMENDATIONS	
Name of Polling Place: Millsboro Town Hall	County: Sussex
Address: 322 Wilson Highway, Millsboro	
Contact Person(s) Assisting Survey: Cara Hartsky	
Voting Area: Town Hall	

FINDINGS AND RECOMMENDATIONS BASED ON ON-SITE SURVEY AND ADA REQUIREMENTS	
Survey Performed by: Gray Smith AIA AICP Survey Date: June 15, 2005	
<p>Note: This building contains 2 polling places: Civic Center; Town Hall – each with its own entrance.)</p> <p>1. Parking: The parking spaces at the Town Hall entrance are all labeled “reserved” with signs; none are designated accessible. A portable “handicapped” sign is stored inside the entrance.</p> <p>Recommendation: Designate the 2 parking spaces on either side of the entrance walkway as van-accessible with permanent upright signs at 5 feet high, with “van-accessible” signs. Add striping to the surfaces of the aisle in front of the entry walkway.</p>	



Gray Smith's Office

Architecture & Community Development
Expert Analysis & Testimony

Name of Polling Place: Millsboro Town Hall **County:** Sussex

FINDINGS AND RECOMMENDATIONS BASED ON ON-SITE SURVEY AND ADA REQUIREMENTS

Survey Performed by: Gray Smith AIA AICP

Survey Date: June 15, 2005



- 2. Entry walkway:** There was a 3 to 4 inches high vertical edge at the transition between the parking lot and the entry walkway.

Recommendation: Replace half of the entry walkway with a new, sloped concrete walkway, level at the bottom with the parking surface.

(Note: An employee of the town advised that some construction work was planned for this area.)



Gray Smith's Office

Architecture & Community Development
Expert Analysis & Testimony

Name of Polling Place: Millsboro Town Hall **County:** Sussex

FINDINGS AND RECOMMENDATIONS BASED ON ON-SITE SURVEY AND ADA REQUIREMENTS

Survey Performed by: Gray Smith AIA AICP

Survey Date: June 15, 2005

- 3. Entrance door:** The entrance door requires a push pressure of 15 pounds to open. There are doorknobs on the door.

Recommendation: Adjust or replace automatic door closer to assure maximum 5 pounds push pressure. Replace doorknobs with lever handles.



Gray Smith's Office

Architecture & Community Development
Expert Analysis & Testimony

DELAWARE COMMISSIONER OF ELECTIONS POLLING PLACE ACCESSIBILITY RECOMMENDATIONS	
Name of Polling Place: Gumboro Fire Hall	County: Sussex
Address: 37030 Millsboro Highway, Millsboro	
Contact Person(s) Assisting Survey: Wayne Osborn	
Voting Area: Volunteer Fire Hall: Social Hall	

FINDINGS AND RECOMMENDATIONS BASED ON ON-SITE SURVEY AND ADA REQUIREMENTS

Survey Performed by: Gray Smith AIA AICP

Survey Date: June 15, 2005

- 1. Parking:** Accessible parking spaces were provided; however, there was no van-accessible space and no signs. The surface paint was wearing away.

Recommendation: Reconfigure and repaint to provide accessible spaces with one van-accessible space and side access aisles as indicated in the drawing below. Install wall-mounted signs at 5 feet high, including "van-accessible" sign.

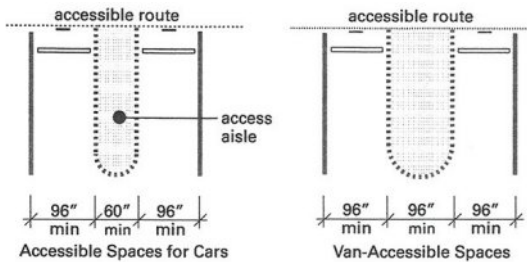

Gray Smith's Office

Architecture & Community Development
Expert Analysis & Testimony

Name of Polling Place: Gumboro Fire Hall **County:** Sussex

FINDINGS AND RECOMMENDATIONS BASED ON ON-SITE SURVEY AND ADA REQUIREMENTS

Survey Performed by: Gray Smith AIA AICP

Survey Date: June 15, 2005

2. Entrance door: The entrance door had doorknobs.

Recommendation: Replace doorknobs with lever handles.



Gray Smith's Office

Architecture & Community Development
Expert Analysis & Testimony

DELAWARE COMMISSIONER OF ELECTIONS POLLING PLACE ACCESSIBILITY RECOMMENDATIONS	
Name of Polling Place: Delmar Fire Hall	County: Sussex
Address: Grove & Bi-State Boulevard, Delmar	
Contact Person(s) Assisting Survey: Wayne Osborn	
Voting Area: Volunteer Fire Hall: Engine Room	

FINDINGS AND RECOMMENDATIONS BASED ON ON-SITE SURVEY AND ADA REQUIREMENTS
Survey Performed by: Gray Smith AIA AICP
Survey Date: June 15, 2005

- 1. Parking:** Accessible parking spaces were provided; however, there were no side access aisles, no van-accessible space and no upright signs.

Recommendation: Reconfigure and repaint accessible spaces to include a van-accessible space and side access aisles, as indicated in the drawing below. Add upright signs at 5 feet high, including "van-accessible" sign. Install wheelstops to prevent vehicle contact with signs.

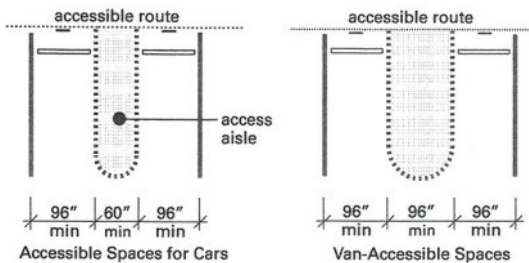

Gray Smith's Office

Architecture & Community Development
Expert Analysis & Testimony

Name of Polling Place: Delmar Fire Hall **County:** Sussex

FINDINGS AND RECOMMENDATIONS BASED ON ON-SITE SURVEY AND ADA REQUIREMENTS

Survey Performed by: Gray Smith AIA AICP

Survey Date: June 15, 2005

- 2. Entrance door:** Entrance door requires 10 pounds of push pressure to open.

Recommendation: Adjust or replace automatic door closer to assure maximum 5 pounds push pressure.



Gray Smith's Office

Architecture & Community Development
Expert Analysis & Testimony

DELAWARE COMMISSIONER OF ELECTIONS POLLING PLACE ACCESSIBILITY RECOMMENDATIONS	
Name of Polling Place: Frankford Fire Hall	
County: Sussex	
Address: 7 Main Street, Frankford	
Contact Person(s) Assisting Survey: Wayne Osborn	
Voting Area: Volunteer Fire Hall: Engine Room	

FINDINGS AND RECOMMENDATIONS BASED ON ON-SITE SURVEY AND ADA REQUIREMENTS	
Survey Performed by: Gray Smith AIA AICP Survey Date: June 15, 2005	
<p>Note: Entry was not available at this facility during the visit.</p> <p>Parking: Accessible parking spaces were provided; however, the surface paint was wearing away.</p> <p>Recommendation: Repaint surface at all accessible spaces.</p>	

Gray Smith's Office

Architecture & Community Development
Expert Analysis & Testimony

DELAWARE COMMISSIONER OF ELECTIONS POLLING PLACE ACCESSIBILITY RECOMMENDATIONS	
Name of Polling Place: Roxana Fire Hall Station 90	County: Sussex
Address: Zion Church Road, Frankford	
Contact Person(s) Assisting Survey: Wayne Osborn	
Voting Area: Volunteer Fire Hall: Engine Room	

FINDINGS AND RECOMMENDATIONS BASED ON ON-SITE SURVEY AND ADA REQUIREMENTS	
Survey Performed by: Gray Smith AIA AICP Survey Date: June 15, 2005	
<p>Entrance door: Entrance door required a push pressure of 12 pounds to open.</p> <p>Recommendation: Adjust or replace automatic door closer to assure a maximum 5 pounds push pressure.</p>	 

Gray Smith's Office

Architecture & Community Development
Expert Analysis & Testimony

DELAWARE COMMISSIONER OF ELECTIONS POLLING PLACE ACCESSIBILITY RECOMMENDATIONS	
Name of Polling Place: Roxana Sub Station #2	County: Sussex
Address: Lt. House Road, Selbyville	
Contact Person(s) Assisting Survey: Wayne Osborne	
Voting Area: Volunteer Fire Hall: Engine Room	

FINDINGS AND RECOMMENDATIONS BASED ON ON-SITE SURVEY AND ADA REQUIREMENTS
Survey Performed by: Gray Smith AIA AICP
Survey Date: June 15, 2005

Note: Entry was unavailable at this facility during the visit.

- 1. Parking:** There were no designated accessible parking spaces on the paved apron or gravel parking areas.

Recommendation: At one of the currently gravel parking areas, pave an area sufficient for accessible parking spaces, a van-accessible space and side access aisles as indicated in the drawing below. Include upright signs at 5 feet high with a "van-accessible" sign.

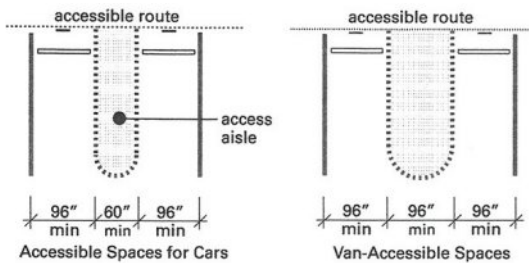

Gray Smith's Office

Architecture & Community Development
Expert Analysis & Testimony

Name of Polling Place: Roxana Sub Station #2 **County:** Sussex

FINDINGS AND RECOMMENDATIONS BASED ON ON-SITE SURVEY AND ADA REQUIREMENTS

Survey Performed by: Gray Smith AIA AICP

Survey Date: June 15, 2005



- 2. Exit door:** The current entrance to the polling place is on the left side of the building, and the exit is on the right side. Whereas the entrance door has lever handles, the exit door has doorknobs.

Recommendation: Replace the doorknobs with lever handles.



Gray Smith's Office

Architecture & Community Development
Expert Analysis & Testimony

DELAWARE COMMISSIONER OF ELECTIONS POLLING PLACE ACCESSIBILITY RECOMMENDATIONS	
Name of Polling Place: Millville Fire Hall	County: Sussex
Address: 316 Atlantic Avenue, Millville	
Contact Person(s) Assisting Survey: Wayne Osborn	
Voting Area: Volunteer Fire Hall	

FINDINGS AND RECOMMENDATIONS BASED ON ON-SITE SURVEY AND ADA REQUIREMENTS
Survey Performed by: Gray Smith AIA AICP
Survey Date: June 15, 2005

1. Parking: Accessible parking spaces are provided; however, some side access aisles are missing and some do not have upright signs. There is no "van-accessible" sign.

Recommendation: Reconfigure and repaint surface to provide access aisles and van-accessible space as indicated in the drawing below. Add upright signs and "van-accessible" sign.

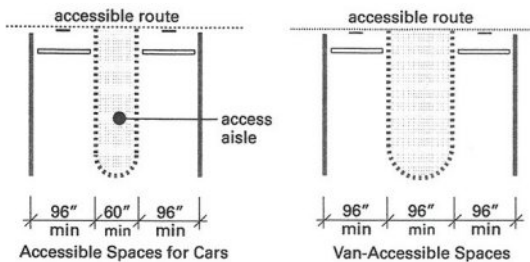

Gray Smith's Office

Architecture & Community Development
Expert Analysis & Testimony

Name of Polling Place: Millville Fire Hall **County:** Sussex

FINDINGS AND RECOMMENDATIONS BASED ON ON-SITE SURVEY AND ADA REQUIREMENTS

Survey Performed by: Gray Smith AIA AICP

Survey Date: June 15, 2005

- 2. Route to entrance:** Except at entrance, a continuous curb of approximately 3 inches is along the "nose" ends of the parking spaces (where access aisles are proposed).

Recommendation: Provide asphalt, build up curb ramps with gradual slopes at new access aisles.

- 3. Entrance doors:** Two doors are used for entrance and exit. They require 19 to 20 pounds of push pressure to open. One has a raised threshold with an edge higher than ½ inch.

Recommendation: Adjust or replace automatic door closers to assure a maximum 5 pounds push pressure. Replace the raised threshold with a wider, beveled, low-profile, aluminum threshold.



Gray Smith's Office

Architecture & Community Development
Expert Analysis & Testimony

DELAWARE COMMISSIONER OF ELECTIONS POLLING PLACE ACCESSIBILITY RECOMMENDATIONS	
Name of Polling Place: Bethany Beach Fire Hall	County: Sussex
Address: 215 Hollywood Street, Bethany Beach	
Contact Person(s) Assisting Survey: Wayne Osborn	
Voting Area: Volunteer Fire Hall: Engine Room	

FINDINGS AND RECOMMENDATIONS BASED ON ON-SITE SURVEY AND ADA REQUIREMENTS

Survey Performed by: Gray Smith AIA AICP

Survey Date: June 15, 2005

- 1. Parking:** Accessible parking spaces were on-site; however, blocked by a construction trailer for a large addition to the facility.

Recommendation: Assure that accessible spaces are cleared, painted and available on election day.



- 2. Entrance door:** Entrance door requires a push pressure of 12 pounds to open.

Recommendation: Adjust or replace automatic door closer to assure a maximum 5 pounds push pressure.



Gray Smith's Office

Architecture & Community Development
Expert Analysis & Testimony

DELAWARE COMMISSIONER OF ELECTIONS POLLING PLACE ACCESSIBILITY RECOMMENDATIONS	
Name of Polling Place: Fenwick Island Town Hall	County: Sussex
Address: 800 Coastal Highway, Bethany Beach	
Contact Person(s) Assisting Survey: Wayne Osborne	
Voting Area: Town Hall	

FINDINGS AND RECOMMENDATIONS BASED ON ON-SITE SURVEY AND ADA REQUIREMENTS
Survey Performed by: Gray Smith AIA AICP
Survey Date: June 15, 2005

1. Parking: Wide accessible parking spaces were provided; however, there were no side access aisles and no "van-accessible" sign. One accessible space is remote from the entrance.

Recommendation: Relocate, reconfigure and repaint accessible spaces to provide side access aisles and van-accessible space next to the entrance, as indicated in the drawing below. Add "van-accessible" sign.

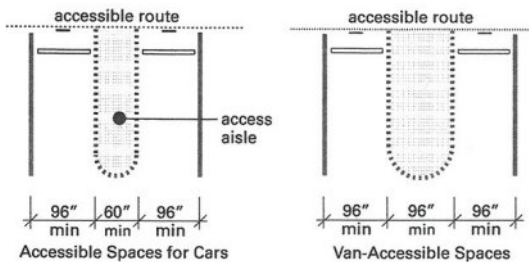

Gray Smith's Office

Architecture & Community Development
Expert Analysis & Testimony

Name of Polling Place: Fenwick Island Town Hall **County:** Sussex
FINDINGS AND RECOMMENDATIONS BASED ON ON-SITE SURVEY AND ADA REQUIREMENTS
Survey Performed by: Gray Smith AIA AICP
Survey Date: June 15, 2005

2. Entrance ramp: The concrete entrance ramp handrails were only 29 ½ inches high and they did not extend to, or 12 inches beyond, the bottom of the ramp.

Recommendation: Add supplemental handrails at 32 to 34 inches high, and add extensions at the bottom ends to 12 inches beyond the surface of the ramp. See drawing below.

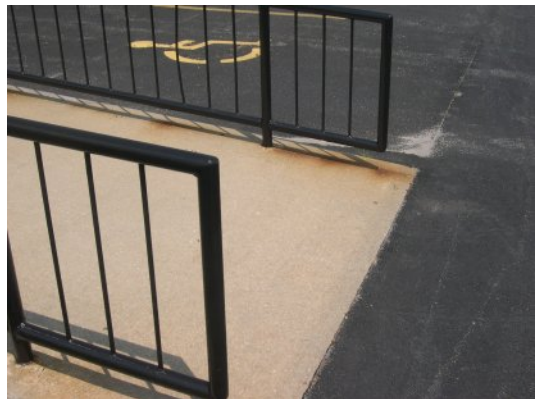
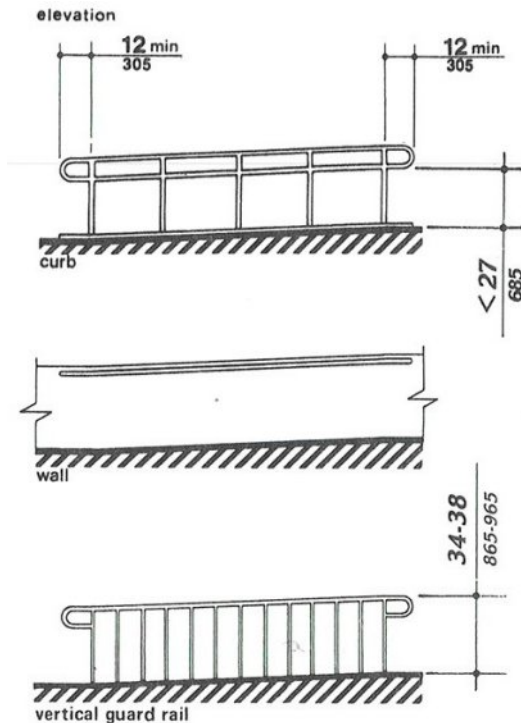

Gray Smith's Office

Architecture & Community Development
Expert Analysis & Testimony

Name of Polling Place: Fenwick Island Town Hall **County:** Sussex
FINDINGS AND RECOMMENDATIONS BASED ON ON-SITE SURVEY AND ADA REQUIREMENTS
Survey Performed by: Gray Smith AIA AICP
Survey Date: June 15, 2005

3. Entrance and Vestibule doors: The entrance doors required a push pressure of 14 pounds to open. Both entrance and Vestibule doors had thresholds with vertical edges of 3/4 inches.

Recommendation: Adjust or replace automatic door closer to assure a maximum 5 pounds push pressure. Replace thresholds with wider, beveled, low-profile, aluminum thresholds.



Gray Smith's Office

Architecture & Community Development
Expert Analysis & Testimony

DELAWARE COMMISSIONER OF ELECTIONS POLLING PLACE ACCESSIBILITY RECOMMENDATIONS	
Name of Polling Place: Rehoboth Beach Fire Hall	County: Sussex
Address: 219 Rehoboth Avenue, Rehoboth	
Contact Person(s) Assisting Survey: Wayne Osborn	
Voting Area: Volunteer Fire Hall	

FINDINGS AND RECOMMENDATIONS BASED ON ON-SITE SURVEY AND ADA REQUIREMENTS

Survey Performed by: Gray Smith AIA AICP
Survey Date: June 15, 2005

Note: Entry was not available to this facility during the visit.

- Parking:** There were no designated accessible parking space at this site.

Recommendation: Designate and surface paint accessible parking spaces with side access aisles and one van-accessible space, as indicated in the drawing below. Include upright sign at 5 feet high and "van-accessible" sign.

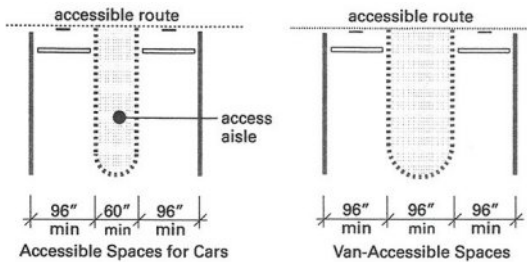

Gray Smith's Office

Architecture & Community Development
Expert Analysis & Testimony

Name of Polling Place: Rehoboth Fire Hall **County:** Sussex
FINDINGS AND RECOMMENDATIONS BASED ON ON-SITE SURVEY AND ADA REQUIREMENTS
Survey Performed by: Gray Smith AIA AICP
Survey Date: June 15, 2005

2. Entrance door: A threshold with a vertical edge greater than 1/2 inch was at the entrance door.

Recommendation: Replace threshold with a wider, beveled, low-profile, aluminum threshold.



Gray Smith's Office

Architecture & Community Development
Expert Analysis & Testimony

DELAWARE COMMISSIONER OF ELECTIONS POLLING PLACE ACCESSIBILITY RECOMMENDATIONS	
Name of Polling Place: Rehoboth Fire Hall (Sub-Station)	
County: Sussex	
Address: 4407 Coastal Highway, Rehoboth	
Contact Person(s) Assisting Survey: Wayne Osborn	
Voting Area: Volunteer Fire Hall: Engine Room	

FINDINGS AND RECOMMENDATIONS BASED ON ON-SITE SURVEY AND ADA REQUIREMENTS
Survey Performed by: Gray Smith AIA AICP
Survey Date: June 15, 2005

Note: Entry was not available to this facility during the visit.

- Parking:** No designated accessible parking spaces were on-site.

Recommendation: Designate and surface paint accessible parking spaces with side access aisles and one van-accessible space, as indicated in the drawing below. Include upright signs at 5 feet high and "van-accessible" sign.

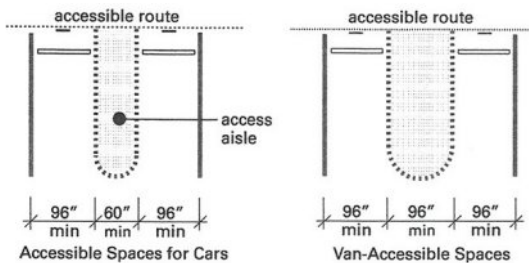

Gray Smith's Office

Architecture & Community Development
Expert Analysis & Testimony

Name of Polling Place: Rehoboth Fire Hall **County:** Sussex

FINDINGS AND RECOMMENDATIONS BASED ON ON-SITE SURVEY AND ADA REQUIREMENTS

Survey Performed by: Gray Smith AIA AICP

Survey Date: June 15, 2005

- 3. Entrance door:** A threshold with a vertical edge greater than $\frac{1}{2}$ inch was at the entrance door.

Recommendation: Replace threshold with a wider, beveled, low-profile, aluminum threshold.

