

POLLING PLACES IN DELAWARE

FINDINGS AND RECOMMENDATIONS FOR COMPLIANCE WITH THE *AMERICANS WITH DISABILITIES ACT (ADA)* AND THE *HELP AMERICA VOTE ACT*

**Prepared for:
State of Delaware
Commissioner of Elections**



Volume I (Fire Halls, Community Centers, Churches and Clubs) **New Castle County**

December, 2005

Gray Smith's Office

Architecture & Community Development
Expert Analysis & Testimony

1219 Locust Street
Philadelphia, PA 19107

Gray Smith's Office

Architecture & Community Development
Expert Analysis & Testimony

CONTENTS

INTRODUCTION

ACKNOWLEDGEMENTS

GRAY SMITH'S OFFICE

Findings and Recommendations: Polling Places in New Castle County

Union United Methodist Church
St. Elizabeth Ann Seton R.C. Church
Bear Library
Red Lion United Methodist Church
Red Lion Evangelical Church
Faith Lutheran Church
Glasgow Reformed Presbyterian
The Good Shepherd Baptist Church
Christiana Fire Company #6
Boys & Girls Clubs of Delaware
Newark Branch Library
Main Towers
Aetna Fire Station #7
First Presbyterian Church
George Wilson Community Center
First Church of the Nazarene
Evangelical Presbyterian Church
Ebenezer Methodist Church
Unitarian Universal St. Millcreek
Chinese-American Community Center
Port Penn Volunteer Fire Company
Odessa Fire Hall
Corbitt-Calloway Library
Blackbird Community Center
Freewill Baptist Church
Wilmington Music School
Police Athletic League
Crestview Apartments
Kingswood Community Center
Wilmington Senior Center
Baynard Apartments
The Park View
Grace Methodist Church
Hicks Anderson Community Center
Quaker Hill Place Apartments
Henrietta Johnson Medical Center

Gray Smith's Office

Architecture & Community Development
Expert Analysis & Testimony

Wilmington Friends School
Lutheran Church/Good Sheperd
First Unitarian Church
Mary Campbell Center
Trinity Presbyterian Church
Gild Hall – Arden Club
Forwood Manor
Shipley Manor
Brandywine Hundred Fire Hall
Hillcrest-Bellefonte Methodist Church
St. David's Episcopal Church
Emmanuel Presbyterian Church
Concord Presbyterian Church
Aldersgate United Methodist Church
Latin-American Community Center
St. Hedwig's Catholic Church
Girls, Inc. – Dennison Branch
West End Neighborhood House
Zion Lutheran Church
Elsmere Fire Company #1
Elsmere Public Library & Elsmere Town Hall
Five Points Fire Hall
Peniel United Methodist Church
Nur Shriners (Nur Temple)
B'Nai B'Rith House
Captain's Deck
Rosehill Community Center
Minquadale Fire Company
Howard Weston Senior Center
New Castle United Methodist Church
Goodwill Fire Company
Victory Christian Fellowship
Cokesbury Village
Hockessin Fire Company
Hockessin Police Athletic League
Hockessin Public Library
Delaware City Library & Community Center
Westminster Presbyterian Church
Luther Towers
Lincoln Apartments
Immanuel Church, Highlands
Tatnall School
Methodist Country House
Lower Brandywine Presbyterian Church
St. Philip's Lutheran Church
St. James Church Parish House
St. Catherine of Siena Church
Mill Creek Fire Company

Gray Smith's Office

Architecture & Community Development
Expert Analysis & Testimony

Manor Care Health Services
Limestone Presbyterian Church
Mid-County Senior Center

INTRODUCTION

This volume is one of three, one for each County in Delaware, documenting information obtained from surveys of 127 polling places in the state. The purpose of the effort was to identify, at each site, the physical conditions that create architectural barriers to disabled persons, which might prevent them from voting, or would otherwise be hazardous to disabled persons. The basis for the analysis was the federal *Help America Vote Act* and the *Americans with Disabilities Act (ADA)*.

It was noted that the staffs of the Departments of Elections for Kent, New Castle and Sussex Counties had made great strides toward improving polling place accessibility before this study was assigned. Those efforts included extensive mitigations of a temporary nature, including detailed site surveys and drawings, portable signs, and personal assistance. The Departments' staffs were frequently called upon to review and advise on changes at polling places that might affect accessibility.

Report format: An individual report has been prepared for each polling place site and building. A corrective action is recommended for each defective condition, so as permanently to provide *ADA* compliance. The reports are intentionally formatted in 3-ring binders, and also electronically for computer review. Each site report can be shared with the stakeholders for that site.

Implementation: There are several ways to undertake the physical work outlined to improve conditions for accessibility. Virtually every activity involves some design work and construction. Based on the sources of funds and the applicable procurement policies, there are several methods to consider:

Gray Smith's Office

Architecture & Community Development
Expert Analysis & Testimony

- Require each polling place owner to implement the corrections, either with their own funds or reimbursed with public funds.
- Engage state or county governmental agency(s) to contract for architectural design and construction at all or most of the sites, perhaps in multiples.
- Undertake a combination of the 2, based on local preferences.

In any event, there are several unavoidable steps in the process of performing the corrections at a polling place:

- Architectural and/or engineering drawings detailing the work to be performed.
- Some or all of: a Building Permit; Department of Streets Permit; Electrical Permit.
- A construction contract for the work, with all of the standard safeguards.
- Inspections of the work by the architect and/or engineer, and the local Codes Official.
- Verification of correct completion relayed to the Election Commission, and the County Departments of Elections.

Regulatory requirements: It was observed during the course of the surveys that many of the non-accessibility features were also in violation of other regulatory requirements expected of the facilities, even if it were not a polling place. Most of the defects were not in compliance with the *Americans with Disabilities Act Accessibility Guidelines (ADAAG)*, the *Fair Housing Act Fair Housing Accessibility Guidelines*, state accessibility regulations, and/or local Building Codes. It is strongly recommended that the owners of each facility visited consult with architects to assure that full regulatory compliance is pursued when the work is designed.

Gray Smith's Office

Architecture & Community Development
Expert Analysis & Testimony

Details to consider: During implementation of the recommendations, it will be important for those undertaking the design and construction to consider the following:

- **Parking availability:** On election day, it was suggested that at least 2 accessible parking spaces be made available – all day – for disabled voters. At some locations, this effort might exclude daily users who might otherwise be using the parking spaces. In some instances, it was clear that fewer accessible spaces were provided at the site than were required by the various regulations noted above. Many locations had no van-accessible spaces, although required by regulations to do so. The County Departments of Elections compensated in some cases by temporarily identifying and reserving regular parking spaces for disabled voters on election day. It will therefore be necessary at each site to determine the full total of accessible and van-accessible spaces required by regulation – in most cases more than 2 spaces alone. Once achieved, the Departments of Elections can simply identify and preserve, with portable signage, 2 permanently accessible parking spaces for election day in cooperation with the property owner.
- **Parking signs:** Upright signs are required for every permanent accessible parking space. Signage used for identifying accessible parking spaces were observed at the polling place with many different messages. Several were in accordance with the Delaware Department of Transportation regulations (see below). Many were not. It is recommended that parking signs at each site be replaced with the correctly worded sign, if not currently correct. Signs should be wall-mounted if a wall is available, or on a permanent upright sign post, at 5 feet high.

Gray Smith's Office

Architecture & Community Development
Expert Analysis & Testimony



Source: DE Department of Transportation

A supplemental sign for van-accessible parking spaces: VAN-ACCESSIBLE – can be placed below the official sign shown above.

- **“handicapped”**: Use of the term “handicapped” has become archaic, in that the disabled community has determined that the term does not accurately represent the character of physically disabled persons. It has been demonstrated that the international blue wheelchair symbol (as seen on the sign above) is now universally recognized for its meaning. As such, it is recommended that, where “handicapped” now appears on any signs at polling places, it be replaced with the symbol. Should the written word be necessary in some cases, “disabled” and “accessible” are acceptable terms.
- **Surface painting**: General parking surface striping is usually undertaken with white or yellow paint. Surface paint used for accessible parking spaces, side access aisles, accessible routes and crosswalks specifically for disabled persons, and accessibility symbols are recommended to be medium to light blue, depending on the darkness of the paved surface. Periodic repainting is also necessary due to wear.

Gray Smith's Office

Architecture & Community Development
Expert Analysis & Testimony

- **Snow and ice:** As most polling places, the potential for surface accumulation of ice and snow is high during inclement weather. Arrangements should be made to assure availability of melting chemicals before and during election day.

Finally, it is suggested that the corrective work performed at each location be documented with digital cameras when completed and transmitted to the appropriate Department of Elections and to the Commissioner of Elections. This activity, when recorded, will verify compliance. Such documentation can be made a requirement of a construction contract.

Gray Smith's Office

Architecture & Community Development
Expert Analysis & Testimony

ACKNOWLEDGEMENTS

The efforts undertaken to produce this study were made possible through the leadership and funding from Delaware's Commissioner of Elections, Frank B. Calio and his staff. Assisting in the 11, day-long trips to polling places were Cara Hartsky (Department of Elections for New Castle County), Barbara Lippincott (Department of Elections for New Castle County), Gary Hilderband (Department of Elections for Kent County) and Wayne Osborn (Department of Elections for Sussex County), who also made sure no one got lost. A well-drawn set of diagrams on temporary election day signage and parking locations at many of the sites was very helpful.

Encouragement was received from the Delaware Disabilities Law Program, Laura J. Waterland, Esquire.

Finally, Kimberly Latona, Office Manager and Gray Smith's Office overall computer expert, developed the intricate layouts for the survey forms and books, and the final report. They are easy to understand and follow up with productive action.

Reference was made to a number of key federal and local publications oriented toward making the polling places accessible to disabled persons. They are recommended for anyone concerned with this important goal.

1. *Americans with Disabilities Act ADA Checklist for Polling Places*, U.S. Department of Justice, Civil Rights Division, Disability Rights Section, February 2004. Copies available for download: www.ada.gov or by calling the ADA Information Line at 800-514-0301 (voice), 800-514-0383 (TTY).

Gray Smith's Office

Architecture & Community Development
Expert Analysis & Testimony

2. *Code of Federal Regulations: 28 CFR Part 36*, Revised as of July 1, 1994 – *Nondiscrimination on the Basis of Disability by Public Accommodations and in Commercial Facilities*, which includes the *Americans with Disabilities Act Accessibility Guidelines (ADAAG)*.
3. *ADAAG Manual: a guide to the Americans with Disabilities Act Accessibility Guidelines*, U.S. Architectural and Transportation Barrier Compliance Board, July 1998.
4. *State of Delaware – STATE PLAN – Help America Vote Act*, September 15, 2003, Frank B. Calio, Commissioner of Elections.
5. Brochure: *Voting is Easy in Delaware!*, State of Delaware Commission of Elections.
6. *Disabilities Law Program Primary Accessibility Survey*, Community Legal Aid Society, Inc., Wilmington, DE, May 5, 2004.
7. “The Face of Accessibility in the Voting Process”, *Outlooks, A Newsletter from the Pennsylvania Developmental Disabilities Council*, Fall 2002.
8. “Help America Vote Act: New Law Includes Provisions for Access”, *ADA & IT in focus*, a publication of the ADA & IT Information Center for the Mid-Atlantic Region, Fall 2003.

With appreciation to all that helped:

Gray Smith AIA AICP

Gray Smith's Office

Architecture & Community Development
Expert Analysis & Testimony

GRAY SMITH AIA AICP

Gray Smith AIA AICP, is the owner of **Gray Smith's Office**, an architectural and urban planning consulting practice. The firm has undertaken many construction projects with an equal emphasis on rehabilitation, historic preservation and new construction, including complex housing, commercial and institutional projects. For governments and non-profit organizations, the firm completed numerous inner-city and downtown planning studies. **Gray Smith's Office** also provides services in forensic analysis and testimony on premises liability, construction litigation, accessibility for disabled persons, planning and zoning, and related disputes.

Mr. Smith was a founding board member of the **Preservation Coalition of Greater Philadelphia**. He was President of the **Philadelphia Chapter of the American Institute of Architects (AIA)** in 1982 and Chair of its Urban Design Committee. He is a member of the **American Institute of Certified Planners (AICP)**, **International Code Council**, and the **National Fire Prevention Association (NFPA)**. He is a shareholder in the **Atheneum of Philadelphia**.

Gray Smith has served as board member of the **Citizens Coalition for Energy Efficiency (C2E2)**, and the **Housing Consortium for Disabled Individuals (HCDI)**. He was a member of the **Philadelphia Bar Association's Investigative Division of the Commission on Judicial Selection and Retention**, an arbitration panelist for the **American Arbitration Association (AAA) Construction Division**, and is a technical advisor to the **SeniorLaw Center**. He has been Chairperson of the Zoning and Code Enforcement Committees of the **South Street Neighborhood Association (SSNA)**, and the **Bella Vista Civic Association**, and Chair of the **SSNA Liquor Control Committee**. Mr. Smith is a past **SSNA** President.

In Philadelphia, Gray Smith was appointed by Mayor Wilson Goode to the **Mayor's Task Force on the Schuylkill Falls Housing Project**, and served on Councilman Ed Schwartz's **Task Force on Neighborhood Resources** and on the **Managing Director's South Street Task Force**. He participated in the **Adaptable Housing Standards Committee** in amending the Philadelphia Building Codes, and was a consultant to the **Fire Safety Committee** of the **Boarding Home Residents Task Force** regarding City Fire Code revisions. The firm produced the **Stair Injury Prevention Manual** for the Philadelphia Injury Prevention Program of the City Health Department. Mr. Smith is a member of the **Barrier-Free Design Committee** of the **Mayor's Commission on Persons with Disabilities**.

In 2003, Mr. Smith received the Regional Award for accessibility advocacy from the **Inglis Foundation of Philadelphia**. He received the 1995 Preservation Achievement Award from the **Philadelphia Historic Preservation Corporation**.

In 1998, 1999 and 2000, Mr. Smith was appointed by the **International Code Council** to serve on the **International Zoning Code Committee**, and the **International Property Maintenance Code Development Committee**, in the annual code change review process. In April 2005, he conducted a seminar on *The Construction Code System in Philadelphia* for the **Lorman Education Services** continuing education program. He serves on the Advisory Committee for the **ADA & IT Information Center for the Mid-Atlantic Region**. He is a member of the **Inclusive Communities Working Group** of the **Housing Alliance of PA**.

Mr. Smith has a Masters degree from **Tulane University School of Architecture** (1965) in New Orleans. He was a **Loeb Fellow in Advanced Environmental Studies** at the **Harvard Graduate School of Design** (1973-74). He is licensed to practice in Pennsylvania, New Jersey and Delaware.

Gray Smith's Office

Architecture & Community Development
Expert Analysis & Testimony

Mr. Smith authored a column in the *Philadelphia City Paper* on "Endangered Buildings and Places". He has presented many lectures and invited papers, and has been a contributor to the *Philadelphia Daily News* and *Philadelphia Inquirer* newspapers.

11.05

Polling Place Accessibility Surveys

New Castle County

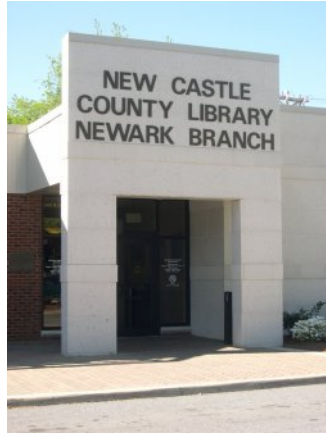

Gray Smith's Office

Architecture & Community Development
Expert Analysis & Testimony

DELAWARE COMMISSIONER OF ELECTIONS POLLING PLACE ACCESSIBILITY RECOMMENDATIONS	
Name of Polling Place: <i>Union United Methodist Church</i>	County: New Castle
Address: 345 School Bell Road, Bear	
Contact Person(s) Assisting Survey: Cara Hartsky	
Voting Area: Church: Multi-purpose Fellowship Hall	

FINDINGS AND RECOMMENDATIONS BASED ON ON-SITE SURVEY AND ADA REQUIREMENTS
Survey Performed by: Gray Smith AIA AICP
Survey Date: May 4, 2005

1. Parking: Seven parking spaces are marked as accessible; however, there are insufficient access aisles. Also, painted striping has faded.

Recommendation: Re-paint accessible spaces to provide access aisles as indicated in the following diagram:

96" min | 60" min | 96" min

Accessible Spaces for Cars

96" min | 96" min | 96" min

Van-Accessible Spaces

1. Parking: Seven parking spaces are marked as accessible; however, there are insufficient access aisles. Also, painted striping has faded.

Gray Smith's Office

Architecture & Community Development
Expert Analysis & Testimony

Name of Polling Place: Union United Methodist Church **County:** New Castle
FINDINGS AND RECOMMENDATIONS BASED ON ON-SITE SURVEY AND ADA REQUIREMENTS
Survey Performed by: Gray Smith AIA AICP
Survey Date: May 4, 2005

2. Curb Ramps: The curb ramps (2) from the Parking area nearest the voting area is located such that disabled persons must go through a driveway and behind parking and un-parking vehicles. There are no curb ramps at the walkways at the curbs adjacent to the “nose” end of the accessible parking spaces.

Recommendation: Reconfigure the “nose” end of the accessible parking area to provide a painted accessible route on the parking surface, minimum 36 inches wide. At the locations where a walkway intersects the curb along the new route, construct a new concrete curb ramp in accordance with the following diagram. Install wheelstops or each accessible parking space to prevent encroachment onto accessible route.

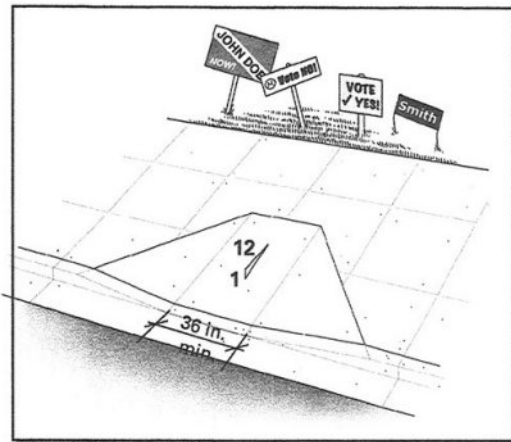

Curb ramp showing minimum 36 inch width for ramp section and 1:12 slope on ramp section.

Note: A portable ramp is also acceptable but a less desirable alternative.

Gray Smith's Office

Architecture & Community Development
Expert Analysis & Testimony

Name of Polling Place: Union United Methodist Church **County:** New Castle
FINDINGS AND RECOMMENDATIONS BASED ON ON-SITE SURVEY AND ADA REQUIREMENTS
Survey Performed by: Gray Smith AIA AICP
Survey Date: May 4, 2005

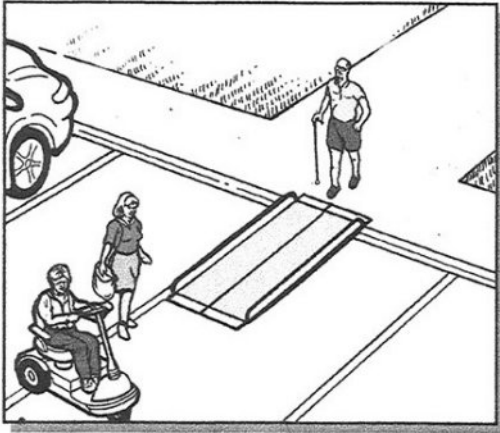

A portable ramp with edge protection is installed over a curb to provide an accessible route.

3. **Entrance door:** The operable leaf of the double-leaf entrance door requires 15 pounds of pressure to push open. The threshold at the entrance door has a 1-inch high obstruction.

Recommendation: a) Reduce the push pressure on the door by: (1) adjusting the automatic door closer; (2) replacing the automatic door closer; (or (3) assuring that a poll worker is available to open the door for persons unable to push it open. b) Replace the threshold with a wider, beveled, low-profile, aluminum threshold.



Gray Smith's Office

Architecture & Community Development
Expert Analysis & Testimony

DELAWARE COMMISSIONER OF ELECTIONS POLLING PLACE ACCESSIBILITY RECOMMENDATIONS	
Name of Polling Place: St. Elizabeth Ann Seton R.C. Church	County: New Castle
Address: 345 Bear-Christiana Road	
Contact Person(s) Assisting Survey: Cara Hartsky	
Voting Area: Church: Multi-purpose Social Hall	

FINDINGS AND RECOMMENDATIONS BASED ON ON-SITE SURVEY AND ADA REQUIREMENTS

Survey Performed by: Gray Smith AIA AICP
Survey Date: May 4, 2005

- Parking:** Only 2 parking spaces are near the entrance, marked on the paved surface as accessible. There are no designating upright signs and no access aisles. There is no accessible route at the "nose" end of the parking spaces such that disabled persons must travel within a driveway and behind parking and unparking vehicles. There is no van-accessible parking space.

Recommendation: Reconfigure the several parking spaces at the location of the existing accessible spaces to form at least 2 parking spaces (one of which is van-accessible) and access aisles. See drawing below. Install upright signs at 5 feet high, with "van-accessible" sign. Paint surfaces with blue paint.

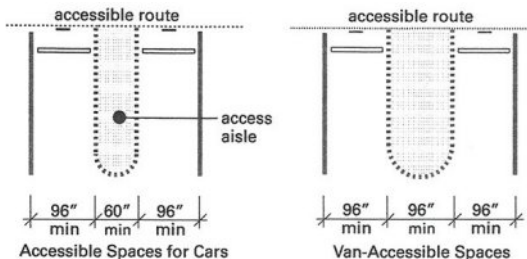

Gray Smith's Office

Architecture & Community Development
Expert Analysis & Testimony

Name of Polling Place: St. Elizabeth Ann Seton R.C. Church **County:** New Castle
FINDINGS AND RECOMMENDATIONS BASED ON ON-SITE SURVEY AND ADA REQUIREMENTS
Survey Performed by: Gray Smith AIA AICP
Survey Date: May 4, 2005



Dedicate at least 36 inches of the nose end of the 3 spaces to a painted accessible route, connecting to the access aisles. Cut through the landscaped peninsula at the corner of the parking spaces and continue the accessible route (paved) to and on the sloped driveway to the front entrance.

- 2. Ramped driveway:** The entrance to the polling place is at the top of a relatively long driveway that is continually sloped and has no intermediate landings and no handrails.

Recommendation: Install a single 36 inches high handrail along the outside of the ramped portion of the driveway. Assure that personnel is available to assist persons in wheelchairs to ascend and descend the ramped area safely.

- 3. Entrance doors:** The double-leaf entrance doors have a concrete bump at the outside of the threshold, which exceeds $\frac{1}{2}$ inch and is an obstruction. The operable door has a push pressure of 8 pounds.

Recommendation: Cut down the concrete bump with a masonry saw to a tapered shape, and patch with epoxy cement. Adjust the automatic door closer to 5 pounds push pressure or less.



Gray Smith's Office

Architecture & Community Development
Expert Analysis & Testimony

DELAWARE COMMISSIONER OF ELECTIONS POLLING PLACE ACCESSIBILITY RECOMMENDATIONS	
Name of Polling Place: Bear Library	County: New Castle
Address: 101 Governors Place, Bear	
Contact Person(s) Assisting Survey: Cara Hartsky	
Voting Area: Public Library: Community Room #1	

FINDINGS AND RECOMMENDATIONS BASED ON ON-SITE SURVEY AND ADA REQUIREMENTS

Survey Performed by: Gray Smith AIA AICP
Survey Date: May 4, 2005

- 1. Parking:** There are 4 accessible parking spaces, 3 of which are van-accessible. None, however, have upright signs.

Recommendation: Provide 4 upright signs (3 designating van-accessible spaces) at the "nose" ends of the 4 parking spaces as per state regulation. Protect the signs with wheelstops.



Gray Smith's Office

Architecture & Community Development
Expert Analysis & Testimony

DELAWARE COMMISSIONER OF ELECTIONS POLLING PLACE ACCESSIBILITY RECOMMENDATIONS	
Name of Polling Place: Red Lion United Methodist Church	County: New Castle
Address: 1545 Church Road, Bear	
Contact Person(s) Assisting Survey: Cara Hartsky	
Voting Area: Church: Fellowship Hall	

FINDINGS AND RECOMMENDATIONS BASED ON ON-SITE SURVEY AND ADA REQUIREMENTS
Survey Performed by: Gray Smith AIA AICP
Survey Date: May 4, 2005

1. Parking: Three parking spaces are designated with signs as accessible. The signs are too low. None have side access aisles. There is no space designated as van-accessible.

Recommendation: Adjust the 3 designated spaces and the adjacent 4th space to provide access aisles as indicated in the following drawing. Include one van-accessible sign. Include upright signs at 5 feet high and “van-accessible” sign(s).

Accessible Spaces for Cars

Van-Accessible Spaces

Gray Smith's Office

Architecture & Community Development
Expert Analysis & Testimony

Name of Polling Place: Red Lion United Methodist Church **County:** New Castle
FINDINGS AND RECOMMENDATIONS BASED ON ON-SITE SURVEY AND ADA REQUIREMENTS
Survey Performed by: Gray Smith AIA AICP
Survey Date: May 4, 2005

- 2. Entrance Door:** The entrance to the Fellowship Hall building is through the Kitchen. The threshold of the door has a 2-inch high lip and a tapered wood piece outside the threshold, with a slight, vertical, front edge.

Recommendation: Replace the threshold with a wider, beveled, low-profile, aluminum threshold with no vertical portions over ½ inch high.

- 3. Obstruction in exterior walkway:** A sign post is located within the entrance walkway that might be a hazard to a sight-impaired person.

Recommendation: Remove sign post. Mount sign on building wall.



Gray Smith's Office

Architecture & Community Development
Expert Analysis & Testimony

DELAWARE COMMISSIONER OF ELECTIONS POLLING PLACE ACCESSIBILITY RECOMMENDATIONS	
Name of Polling Place: Red Lion Evangelical Church	County: New Castle
Address: 1400 Red Lion Road, Bear	
Contact Person(s) Assisting Survey: Cara Hartsky	
Voting Area: Church: Gymnasium	

FINDINGS AND RECOMMENDATIONS BASED ON ON-SITE SURVEY AND ADA REQUIREMENTS	
Survey Performed by: Gray Smith AIA AICP Survey Date: May 4, 2005	
<p>1. Parking: There are 8 parking spaces designated as accessible. None are designated as van-accessible. There are no intermediate access aisles. Disabled pedestrians are required to travel within a traffic lane of the parking lot – behind parking and unparking vehicles.</p> <p>Recommendation: Reconfigure the area of the parking lot to provide fully accessible spaces, including one van-accessible space and access aisles between spaces as per the following diagram. Relocate upright signs at 5 feet high, and add van-accessible indication at that space. Add at the “nose” end of the parking spaces a designated (painted) accessible route, minimum 36 inches wide, and wheel stops to prevent vehicle encroachment. Paint surface with blue paint.</p> <p>At the destination end of the accessible route, construct a curb ramp as per the second diagram below.</p>	

Gray Smith's Office

Architecture & Community Development
Expert Analysis & Testimony

Name of Polling Place: Red Lion Evangelical Church **County:** New Castle
FINDINGS AND RECOMMENDATIONS BASED ON ON-SITE SURVEY AND ADA REQUIREMENTS
Survey Performed by: Gray Smith AIA AICP
Survey Date: May 4, 2005

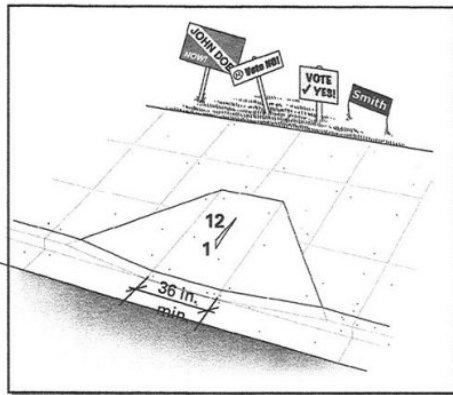
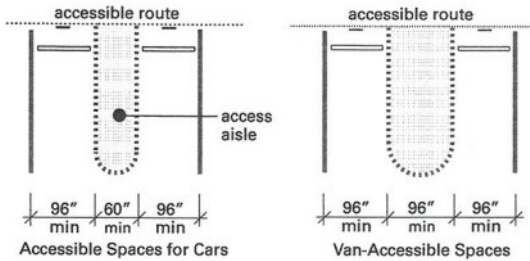

Curb ramp showing minimum 36 inch width for ramp section and 1:12 slope on ramp section.

2. **Entrance door:** The entrance door to the polling place is a double leaf opening with each door opening clearance at less than 34 inches. The opening push pressure from inside measured at 10 pounds.

Recommendation: The 2 doors cannot be propped open during inclement weather. Replace the doors with 2 leaves of different sizes, the main leaf allowing for a full 34 inches clearance (minimum). In the alternative, provide personnel to open the door for wheelchairs on election day. Adjust or replace the automatic door closers (one each door) with closers that assure a maximum of 5 pounds push pressure.

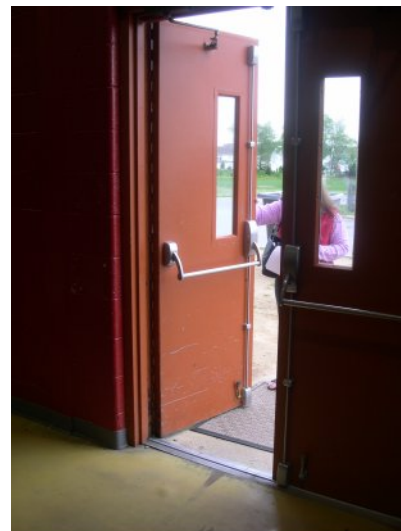

Gray Smith's Office

Architecture & Community Development
Expert Analysis & Testimony

DELAWARE COMMISSIONER OF ELECTIONS POLLING PLACE ACCESSIBILITY RECOMMENDATIONS	
Name of Polling Place: Faith Lutheran Church	County: New Castle
Address: 2265 Red Lion Road, Bear	
Contact Person(s) Assisting Survey: Cara Hartsky	
Voting Area: Church: Narthex	

FINDINGS AND RECOMMENDATIONS BASED ON ON-SITE SURVEY AND ADA REQUIREMENTS

Survey Performed by: Gray Smith AIA AICP
Survey Date: May 4, 2005

- Parking:** There are 4 parking spaces designated as accessible. There is no designated van-accessible space. An access aisle is not located between 2 of the spaces. The surface paint is worn. There are no upright signs designating the accessible spaces. There is no accessible route at the "nose" end of the spaces, requiring disabled persons to travel in the driveway behind parking and unparking vehicles.

Recommendation: Reconfigure the parking spaces to allow for side access aisles and a designated, 36 inches wide (minimum), accessible route at the "nose" end of the spaces. Install 4 upright signs at 5 feet high, including one "van-accessible" sign. Paint surface with blue paint. See diagram below.

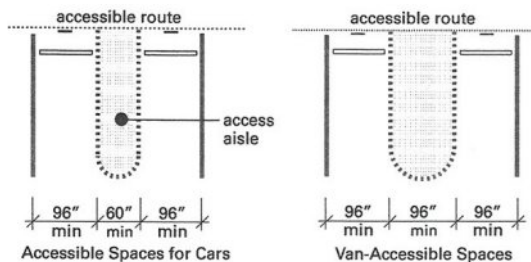

Gray Smith's Office

Architecture & Community Development
Expert Analysis & Testimony

Name of Polling Place: Faith Lutheran Church **County:** New Castle
FINDINGS AND RECOMMENDATIONS BASED ON ON-SITE SURVEY AND ADA REQUIREMENTS
Survey Performed by: Gray Smith AIA AICP
Survey Date: May 4, 2005



2. **Ramped route to entrance:** The route from the parking space to the entrance is along a looped driveway. The driveway is sloped for most of the distance in a slope greater than a 1:10 or 1:12 ratio, greater than allowed for a ramp.

Recommendation: The terrain is such that constructing a fully compliant ramp would be costly, although possible. In the alternative, personnel must be continually alert to the arrival of disabled persons in need of assistance on the ramped surface and provide that assistance. In the alternative, on election days, temporary designated spaces (at least 2) can be positioned near to the entrance; and, to the extent that disabled persons require assistance leaving and entering vehicles, assistance must be provided. Provide temporary disabled voter parking signs.

3. **Entrance door:** The operable leaf of the double leaf entrance door required a push pressure of 10 pounds. The metal threshold had a $\pm \frac{1}{2}$ inch front lip and a second raised position measuring $\pm \frac{3}{4}$ inches vertically.

Recommendation: Adjust or replace the automatic door closer to 5 pounds maximum pressure. Replace the threshold with a wider, beveled, low-profile aluminum threshold.



Gray Smith's Office

Architecture & Community Development
Expert Analysis & Testimony

DELAWARE COMMISSIONER OF ELECTIONS POLLING PLACE ACCESSIBILITY RECOMMENDATIONS	
Name of Polling Place: Glasgow Reformed Presbyterian	County: New Castle
Address: 2880 Summit Bridge Road, Bear	
Contact Person(s) Assisting Survey: Cara Hartsky	
Voting Area: Church: Gymnasium in Family Life Center	

FINDINGS AND RECOMMENDATIONS BASED ON ON-SITE SURVEY AND ADA REQUIREMENTS

Survey Performed by: Gray Smith AIA AICP

Survey Date: May 4, 2005

- 1. Parking:** A significant area is devoted to accessible parking, clearly marked. There are no "van-accessible" designations on the signs, although there are van-accessible spaces.

Recommendation: Install supplemental "van-accessible" signs at all van-accessible spaces.



- 2. Entrance doors:** The larger center entrance door had a 20 pound push pressure.

Recommendation: Adjust or replace automatic door closer to assure a maximum 5 pounds push pressure.



Gray Smith's Office

Architecture & Community Development
Expert Analysis & Testimony

Name of Polling Place: Glasgow Reformed Presbyterian **County:** New Castle

FINDINGS AND RECOMMENDATIONS BASED ON ON-SITE SURVEY AND ADA REQUIREMENTS

Survey Performed by: Gray Smith AIA AICP

Survey Date: May 4, 2005

- 3. Interior doors:** Each of the 2 doors of the double leaf opening provide a clearance of only 28 inches when open.



Recommendation: Prop open both doors throughout election day to assure a minimum 34 inches clear opening.



Gray Smith's Office

Architecture & Community Development
Expert Analysis & Testimony

DELAWARE COMMISSIONER OF ELECTIONS POLLING PLACE ACCESSIBILITY RECOMMENDATIONS	
Name of Polling Place: The Good Shepherd Baptist Church	
County: New Castle	
Address: 2274 Porter Road, Bear	
Contact Person(s) Assisting Survey: Cara Hartsky	
Voting Area: Church: (did not gain access)	

FINDINGS AND RECOMMENDATIONS BASED ON ON-SITE SURVEY AND ADA REQUIREMENTS	
Survey Performed by: Gray Smith AIA AICP Survey Date: May 4, 2005	
<p>Note: Entry was not available to this facility during the visit.</p> <ol style="list-style-type: none">Parking: Although configured for van-accessible parking spaces, there is no “van-accessible” sign. Recommendation: Install supplementary “van-accessible” signs.Entrance doors: Verify that entrance doors have a push pressure of 5 pounds or less. If not, adjust or replace automatic door closers.	 

Gray Smith's Office

Architecture & Community Development
Expert Analysis & Testimony

DELAWARE COMMISSIONER OF ELECTIONS POLLING PLACE ACCESSIBILITY RECOMMENDATIONS	
Name of Polling Place: Christiana Fire Company #6	County: New Castle
Address: 1714 Porter Road, Bear	
Contact Person(s) Assisting Survey: Cara Hartsky	
Voting Area: Volunteer Firehouse: Engine Room (without fire engines)	

FINDINGS AND RECOMMENDATIONS BASED ON ON-SITE SURVEY AND ADA REQUIREMENTS

Survey Performed by: Gray Smith AIA AICP

Survey Date: May 4, 2005

- 1. Parking:** One parking space is designated as accessible. There is no "van-accessible" sign.

Recommendation: Designate the space adjacent to the access aisle as accessible and provide an upright sign at 5 feet high. Provide "van-accessible" signs at both spaces.



Gray Smith's Office

Architecture & Community Development
Expert Analysis & Testimony

Name of Polling Place: Christiana Fire Company #6 **County:** New Castle

FINDINGS AND RECOMMENDATIONS BASED ON ON-SITE SURVEY AND ADA REQUIREMENTS

Survey Performed by: Gray Smith AIA AICP

Survey Date: May 4, 2005

- 2. Entrance door:** The push pressure of the door measured at 10 pounds. The cement under the metal threshold had a raised edge, a portion of which exceeded $\frac{1}{2}$ inch.

Recommendation: Adjust or replace automatic door closer to provide a maximum of 5 pounds push pressure. Provide leveling cement outside the door to compensate for rise at threshold.



- 3. Interior obstructions:** On both sides of the Engine Room are hanging and resting equipment that can create an obstruction to sight-impaired persons.

Recommendation: Assure that, on election day, all activity is away from sides of Engine Room.



Gray Smith's Office

Architecture & Community Development
Expert Analysis & Testimony

DELAWARE COMMISSIONER OF ELECTIONS POLLING PLACE ACCESSIBILITY RECOMMENDATIONS	
Name of Polling Place: Boys & Girls Clubs of Delaware	County: New Castle
Address: 109 Glasgow Drive, Newark	
Contact Person(s) Assisting Survey: Barbara Lippincott	
Voting Area: Youth Activity Center: Community Room	

FINDINGS AND RECOMMENDATIONS BASED ON ON-SITE SURVEY AND ADA REQUIREMENTS
Survey Performed by: Gray Smith AIA AICP
Survey Date: May 9, 2005

1. Parking: There are 2 parking spaces designated for disabled; however, they are related to the playground, not the building; and they are remote from the building entrance.

Recommendation: Reconfigure the parking spaces nearest to the building entrance to provide at least 2 accessible parking spaces, one of which is van-accessible as indicated in the drawing below. Install upright designation signs at least 5 feet high, including "van-accessible" sign. Locate the designated spaces so as to minimize conflict between disabled persons and moving vehicles.

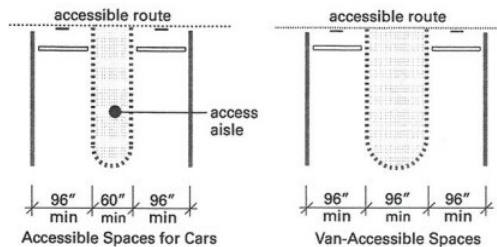

Gray Smith's Office

Architecture & Community Development
Expert Analysis & Testimony

Name of Polling Place: Boys & Girls Club of Delaware **County:** New Castle
FINDINGS AND RECOMMENDATIONS BASED ON ON-SITE SURVEY AND ADA REQUIREMENTS
Survey Performed by: Gray Smith AIA AICP
Survey Date: May 9, 2005



Paint surfaces with blue paint. Provide wheelstops in accessible spaces to prevent vehicle contact with upright signs.



Gray Smith's Office

Architecture & Community Development
Expert Analysis & Testimony

DELAWARE COMMISSIONER OF ELECTIONS POLLING PLACE ACCESSIBILITY RECOMMENDATIONS	
Name of Polling Place: Newark Branch Library	County: New Castle
Address: 750 Library Avenue, Newark	
Contact Person(s) Assisting Survey: Barbara Lippincott	
Voting Area: Public Library: Community Room	

FINDINGS AND RECOMMENDATIONS BASED ON ON-SITE SURVEY AND ADA REQUIREMENTS	
Survey Performed by: Gray Smith AIA AICP Survey Date: May 9, 2005	
<p>1. Parking: Accessible parking spaces, including van-accessible spaces, are provided. There is no "van-accessible" sign. Surface paint is worn. Shrubs obscure signs.</p> <p>Recommendation: Provide supplementary "van-accessible" signs at each van-accessible space. Repaint surfaces with blue paint. Prune shrubs at signs.</p>	

Gray Smith's Office

Architecture & Community Development
Expert Analysis & Testimony

DELAWARE COMMISSIONER OF ELECTIONS POLLING PLACE ACCESSIBILITY RECOMMENDATIONS	
Name of Polling Place: Main Towers	County: New Castle
Address: 330 E. Main Street, Newark	
Contact Person(s) Assisting Survey: Barbara Lippincott	
Voting Area: Senior Housing Apartment Building: Community Room	

FINDINGS AND RECOMMENDATIONS BASED ON ON-SITE SURVEY AND ADA REQUIREMENTS

Survey Performed by: Gray Smith AIA AICP
Survey Date: May 9, 2005

1. Parking: There are several parking spaces marked with upright signs and surface painting; however, they do not have intermediate side access aisles, perhaps because the site is densely populated and parking areas are minimal. The spaces are, however, ample, such that adjustments can be made. Also, disabled persons must cross the driveway to reach the polling place.

Recommendation: Reconfigure and repaint the parking spaces in accordance with the drawing below. In the alternative, on election day, set aside two temporary parking spaces in the driveway near the entrance, with signs for disabled voters.

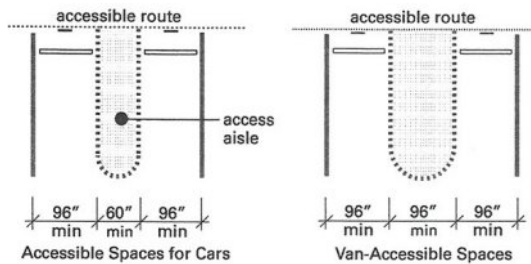

Gray Smith's Office

Architecture & Community Development
Expert Analysis & Testimony

Name of Polling Place: Main Towers **County:** New Castle

FINDINGS AND RECOMMENDATIONS BASED ON ON-SITE SURVEY AND ADA REQUIREMENTS

Survey Performed by: Gray Smith AIA AICP

Survey Date: May 9, 2005



- 2. Entrance Doors:** The polling place opens at 6:00 a.m., however the facility office opens at 8:30 a.m. Entrance and exit between 6 and 8:30 is through an outside Community Room door. An elevated area, higher than ½ inch, is at the threshold of the door, due to settlement of the outside walkway surface.

Recommendation: Repair the concrete at the outside of the door by pouring and keying in a new epoxy concrete surface layer up to the level of the concrete below the metal threshold.

In the alternative, assure that the main entrance to the facility with automatic exterior and Vestibule doors, is unlocked and usable throughout election day and is clearly marked as an accessible entrance for voters.



Gray Smith's Office

Architecture & Community Development
Expert Analysis & Testimony

DELAWARE COMMISSIONER OF ELECTIONS POLLING PLACE ACCESSIBILITY RECOMMENDATIONS	
Name of Polling Place: Aetna Fire Station #7	County: New Castle
Address: 7 Thorn Lane, Newark	
Contact Person(s) Assisting Survey: Barbara Lippincott	
Voting Area: Fire Station: Engine Room	

FINDINGS AND RECOMMENDATIONS BASED ON ON-SITE SURVEY AND ADA REQUIREMENTS
Survey Performed by: Gray Smith AIA AICP
Survey Date: May 9, 2005

- Parking:** There are 2 parking spaces marked accessible, however, there are no upright signs and no side access aisles.

Recommendation: Reconfigure and expand the 2 spaces to provide a central access aisle, as indicated in the drawing below, sized for van-accessible spaces. Also, add 2 upright designating signs at 5 feet high, with "van-accessible" indication.

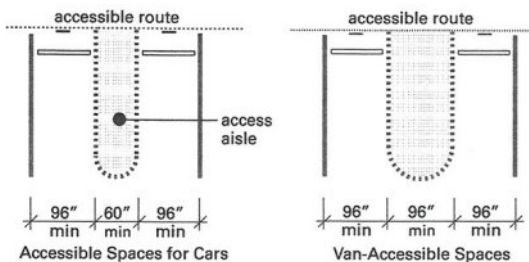

Gray Smith's Office

Architecture & Community Development
Expert Analysis & Testimony

Name of Polling Place: Main Towers **County:** New Castle

FINDINGS AND RECOMMENDATIONS BASED ON ON-SITE SURVEY AND ADA REQUIREMENTS

Survey Performed by: Gray Smith AIA AICP

Survey Date: May 9, 2005

- 2. Entrance door:** The entrance door to the polling place has an elevated area, higher than ½ inch, at the threshold, due to settlement of the concrete driveway surface. Also the door handles are doorknobs not lever handles.

Recommendation: Repair the outside concrete surface by pouring and keying in a new epoxy concrete surface layer up to the level of the concrete below the threshold. Replace the doorknobs with lever handles.



Gray Smith's Office

Architecture & Community Development
Expert Analysis & Testimony

DELAWARE COMMISSIONER OF ELECTIONS POLLING PLACE ACCESSIBILITY RECOMMENDATIONS	
Name of Polling Place: First Presbyterian Church	County: New Castle
Address: 292 W. Main Street, Newark	
Contact Person(s) Assisting Survey: Barbara Lippincott	
Voting Area: Church: "Memorial Hall"	

FINDINGS AND RECOMMENDATIONS BASED ON ON-SITE SURVEY AND ADA REQUIREMENTS

Survey Performed by: Gray Smith AIA AICP

Survey Date: May 9, 2005

- 1. Parking and walkways:** There are no accessible parking spaces nearby to the entrance to the polling place, and no van-accessible parking spaces. The entry walkway adjacent to the Memorial Hall building has a long ramped slope but no handrails and no intermediate landings.

Recommendation: In the wide driveway at the bottom end of the sloped walkway, pave, identify and paint 2 accessible parking spaces with upright signs at 5 feet high, and an access aisle, as indicated on the drawing below. Install handrails on both sides of the ramped walkway. One parking space to be van-accessible.

In the alternative, locate and identify 2 accessible (one van-accessible) parking spaces in the existing parking lot at the end of the curved walkway that passes by the Church building. Install upright signs (one "van-accessible"). Lay out as indicated in the drawing below.



Gray Smith's Office

Architecture & Community Development
Expert Analysis & Testimony

Name of Polling Place: First Presbyterian Church **County:** New Castle
FINDINGS AND RECOMMENDATIONS BASED ON ON-SITE SURVEY AND ADA REQUIREMENTS
Survey Performed by: Gray Smith AIA AICP
Survey Date: May 9, 2005

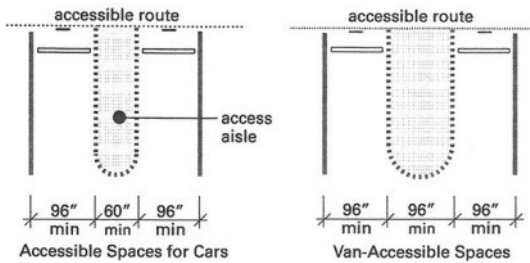

Accessible Spaces for Cars

Van-Accessible Spaces



- 2. Entrance doors:** The main entrance doors are a pair, each less than 32 inches clear when open. Also a 30 pound push pressure is required to open either door. (It was noted that the interior door pair is continuously propped open on election day.)

Recommendation: It was noted that these doors are propped open throughout election day and that a person is stationed at the entrance to assist. In the alternative, replace the 2 doors with an uneven pair, one of which when opened has at least 32 inches clear open area. For either, adjust or replace the automatic door opener to provide a maximum of 5 pounds push pressure.

(Note: A representative of the Church discussed the possibility of relocating the polling place to the Narthex of the Church, or to "Westminster House." The latter possibility, if not in conflict with ongoing activities therein, appeared to be a workable alternative with no new work required. Accessible parking is near and the "Westminster House" building is 100% accessible.)

Gray Smith's Office

Architecture & Community Development
Expert Analysis & Testimony

DELAWARE COMMISSIONER OF ELECTIONS POLLING PLACE ACCESSIBILITY RECOMMENDATIONS	
Name of Polling Place: George Wilson Community Center	County: New Castle
Address: 303 New London Road, Newark	
Contact Person(s) Assisting Survey: Barbara Lippincott	
Voting Area: Community Center: Main Community Room	

FINDINGS AND RECOMMENDATIONS BASED ON ON-SITE SURVEY AND ADA REQUIREMENTS
Survey Performed by: Gray Smith AIA AICP
Survey Date: May 9, 2005

1. Parking: Accessible parking spaces are provided but without access aisles. Upright signs are provided but not protected from vehicular contact.

Recommendation: Repaint accessible space to provide a van-accessible space and side access aisles, as in the drawing below. Add "van-accessible" indication on one upright sign. Install wheelstops in each parking space.

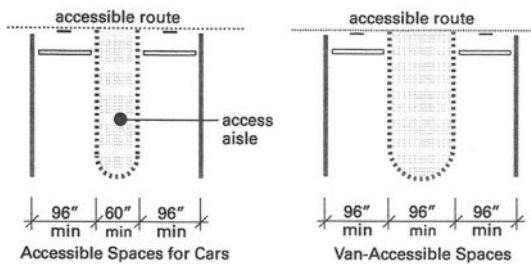

Gray Smith's Office

Architecture & Community Development
Expert Analysis & Testimony

Name of Polling Place: George Wilson Community Center **County:** New Castle
FINDINGS AND RECOMMENDATIONS BASED ON ON-SITE SURVEY AND ADA REQUIREMENTS
Survey Performed by: Gray Smith AIA AICP
Survey Date: May 9, 2005

- 2. Alternate walkway:** The concrete walkway to the accessible entrance requires persons to bypass a closer entrance with steps. The walkway has several cracks and depressions in various locations that create higher than ½ inch edge obstacles.

Recommendation: Repave or repair sections of concrete walkway to eliminate all level changes.

- 3. Entrance ramp:** The ramp has handrails and guardrails on each side, however, there is no guard at the ramp edge to prevent wheelchair wheels from slipping off the edge. There is also a large series of cracks in the ramp that creates a hazard and an obstacle.

Recommendation: Weld 3-inches wide steel plates along the bottom of the handrail posts and paint. Repair/patch the cracks with epoxy cement.



Gray Smith's Office

Architecture & Community Development
Expert Analysis & Testimony

Name of Polling Place: George Wilson Community Center **County:** New Castle
FINDINGS AND RECOMMENDATIONS BASED ON ON-SITE SURVEY AND ADA REQUIREMENTS
Survey Performed by: Gray Smith AIA AICP
Survey Date: May 9, 2005

4. Entrance doors (both ends): The entrance doors require a push pressure of 10 pounds.

Recommendation: Adjust the automatic door closers to a maximum of 5 pounds push pressure.



5. Exterior Stairway: The facility's primary entrance, closest to the parking lot, has steps. There is no handrail on one side and a low inadequate handrail on the other side. Disabled persons not in wheelchairs may enter through this entrance.

Recommendation: Install new pipe handrails on each side of stairway at 34 to 38 inches high above stair nosings. Provide extensions at top and bottom similar to those indicated in the drawing below.

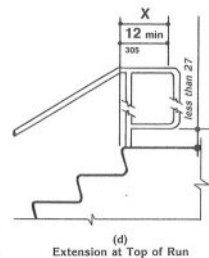
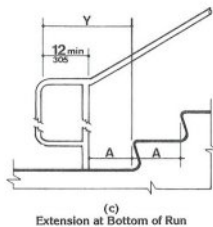

Gray Smith's Office

Architecture & Community Development
Expert Analysis & Testimony

DELAWARE COMMISSIONER OF ELECTIONS POLLING PLACE ACCESSIBILITY RECOMMENDATIONS	
Name of Polling Place: First Church of the Nazarene	County: New Castle
Address: 357 Paper Mill Road, Newark	
Contact Person(s) Assisting Survey: Barbara Lippincott	
Voting Area: Church: "Family Life Center"	

FINDINGS AND RECOMMENDATIONS BASED ON ON-SITE SURVEY AND ADA REQUIREMENTS	
Survey Performed by: Gray Smith AIA AICP Survey Date: May 9, 2005	
<p>1. Parking: The 2 accessible parking spaces and the side access aisle are on a sloped area. The path across the driveway from the accessible spaces to the entrance is partly sloped.</p> <p>Recommendation: Have personnel assistance available to anyone in a wheelchair who might have difficulty traversing the slope.</p>	

Gray Smith's Office

Architecture & Community Development
Expert Analysis & Testimony

DELAWARE COMMISSIONER OF ELECTIONS POLLING PLACE ACCESSIBILITY RECOMMENDATIONS	
Name of Polling Place: Evangelical Presbyterian Church	County: New Castle
Address: 308 Possum Park Road, Newark	
Contact Person(s) Assisting Survey: Barbara Lippincott	
Voting Area: Church: "Family Life Center"	

FINDINGS AND RECOMMENDATIONS BASED ON ON-SITE SURVEY AND ADA REQUIREMENTS

Survey Performed by: Gray Smith AIA AICP
Survey Date: May 9, 2005

- Parking:** Accessible parking spaces on the property are remote and not near the entrance to the polling place. The spaces adjacent to the entrance are conventional.

Recommendation: At the entrance walkway designate a side access aisle (van-accessible type) with accessible parking spaces on each side, in accordance with the drawing below. Erect 2 upright signs at 5 feet high, with one "van-accessible" designation.

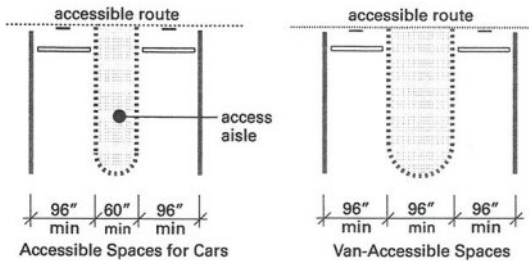

Gray Smith's Office

Architecture & Community Development
Expert Analysis & Testimony

Name of Polling Place: Evangelical Presbyterian Church **County:** New Castle
FINDINGS AND RECOMMENDATIONS BASED ON ON-SITE SURVEY AND ADA REQUIREMENTS
Survey Performed by: Gray Smith AIA AICP
Survey Date: May 9, 2005

- 2. Entrance doors:** Each of the doors in the pair allow for only 28 inches clear, rather 32 inches, when open.

Recommendation: Replace door pair with 2 different size doors, one which allows for 32 inches clear when open. In the alternative, assure that personnel is available to hold both doors open for any person in a wheelchair on election day.



- 3. Interior doors:** Each of the doors in this pair, when open, do not provide 32 inches clear.

Recommendation: Assure that the doors are both propped open throughout election day.



Gray Smith's Office

Architecture & Community Development
Expert Analysis & Testimony

DELAWARE COMMISSIONER OF ELECTIONS POLLING PLACE ACCESSIBILITY RECOMMENDATIONS	
Name of Polling Place: Ebenezer Methodist Church	County: New Castle
Address: 525 Polly Drummond Hill Road, Newark	
Contact Person(s) Assisting Survey: Barbara Lippincott	
Voting Area: Church: Fellowship Hall	

FINDINGS AND RECOMMENDATIONS BASED ON ON-SITE SURVEY AND ADA REQUIREMENTS

Survey Performed by: Gray Smith AIA AICP

Survey Date: May 9, 2005

- 1. Parking:** Six accessible parking spaces with signs are provided; however there is no van-accessible space. The surface paint is worn.

Recommendation: Adjust spacing to allow for 1 van-accessible space and provide "van-accessible" sign. See drawing below. Repaint surface lines.

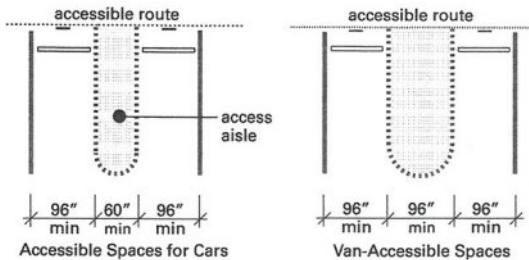

Gray Smith's Office

Architecture & Community Development
Expert Analysis & Testimony

Name of Polling Place: Ebenezer Methodist Church **County:** New Castle

FINDINGS AND RECOMMENDATIONS BASED ON ON-SITE SURVEY AND ADA REQUIREMENTS

Survey Performed by: Gray Smith AIA AICP

Survey Date: May 9, 2005

- 2. Entrance doors:** Each of the doors in this pair, when open, provides 30 inches clear opening, rather than 32 inches. The doors require an 8 pounds push pressure to open.

Recommendation: Replace doors with doors of 2 sizes, one of which, when open, provides a minimum of 32 inches clear. In the alternative, assure that both doors are opened by an assigned person when persons in wheelchairs arrive and depart. Adjust automatic door closer to 5 pounds maximum push pressure.



Gray Smith's Office

Architecture & Community Development
Expert Analysis & Testimony

DELAWARE COMMISSIONER OF ELECTIONS POLLING PLACE ACCESSIBILITY RECOMMENDATIONS	
Name of Polling Place: Unitarian Universal St. Millcreek	County: New Castle
Address: 579 Polly Drummond Hill Road, Newark	
Contact Person(s) Assisting Survey: Barbara Lippincott	
Voting Area: Church: Fellowship-Hall	

FINDINGS AND RECOMMENDATIONS BASED ON ON-SITE SURVEY AND ADA REQUIREMENTS
Survey Performed by: Gray Smith AIA AICP
Survey Date: May 9, 2005

- Parking:** Accessible parking and van-accessible parking is provided, however, no "van-accessible" sign is present.

Recommendation: Install "van-accessible" sign for parking spaces that are van-accessible. See drawing below.

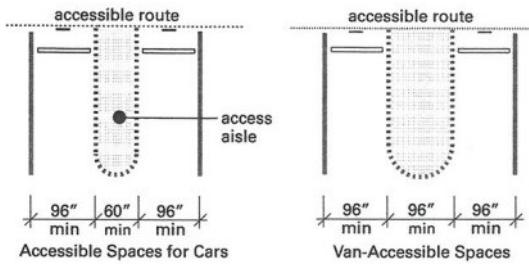

Gray Smith's Office

Architecture & Community Development
Expert Analysis & Testimony

DELAWARE COMMISSIONER OF ELECTIONS POLLING PLACE ACCESSIBILITY RECOMMENDATIONS	
Name of Polling Place: Chinese-American Community Center	
County: New Castle	
Address: Valley & Little Baltimore Roads, Newark	
Contact Person(s) Assisting Survey: Barbara Lippincott	
Voting Area: Community Center: "K-Room"	

FINDINGS AND RECOMMENDATIONS BASED ON ON-SITE SURVEY AND ADA REQUIREMENTS

Survey Performed by: Gray Smith AIA AICP

Survey Date: May 9, 2005

- Parking:** There are no designated accessible or van-accessible parking spaces in 2 parking lots, both remote from entrances (several).

Recommendation: Once a permanent entrance is identified and made accessible, locate a minimum of one accessible space (see below), and one van-accessible space near to the entrance, whether in a parking lot as indicated in the drawing below, or in the front driveway, modified. Provide upright signs, including "van-accessible" sign and surface painting.

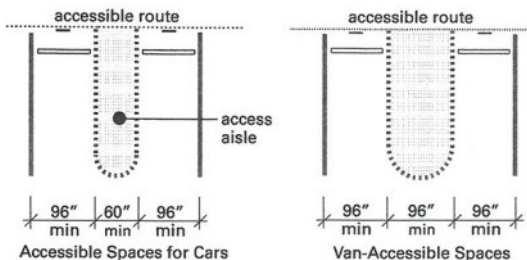

Gray Smith's Office

Architecture & Community Development
Expert Analysis & Testimony

Name of Polling Place: Chinese-American Community Center **County:** New Castle
FINDINGS AND RECOMMENDATIONS BASED ON ON-SITE SURVEY AND ADA REQUIREMENTS
Survey Performed by: Gray Smith AIA AICP
Survey Date: May 9, 2005

2. Entrance: The entrance designated for the polling place is through shrubbery, a cluttered Vestibule and Kitchen – essentially a service entrance. From the Kitchen, one must pass through a Gymnasium (multi-purpose Room), and a long Corridor, to reach the “K-Room” (polling place). There are 2 other primary front entrances along the way, which have single steps, and, in one case, a warped, portable plywood ramp. The latter is the entrance closest to the voting area. (It is noted that these entrances are not in compliance with the *Americans with Disabilities Act (ADA)* for whatever use they serve, and the portable ramp is a hazard.)

Recommendation: Relocate the accessible polling place entrance to one of the primary entrances. At the entrance, construct a 5 feet deep concrete landing outside the doors at the same level as the floor inside. Construct a concrete ramp beyond the landing, sloped at 1:12 and provide handrails on both sides, similar to the drawing below.

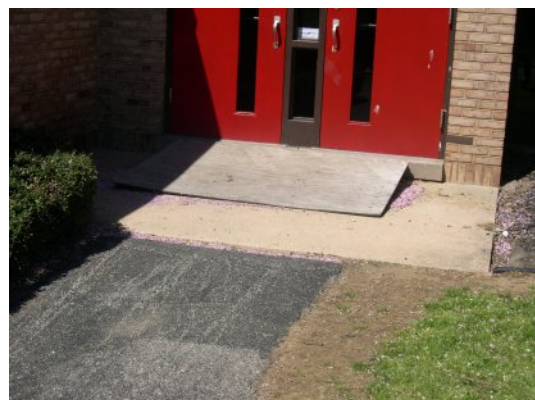
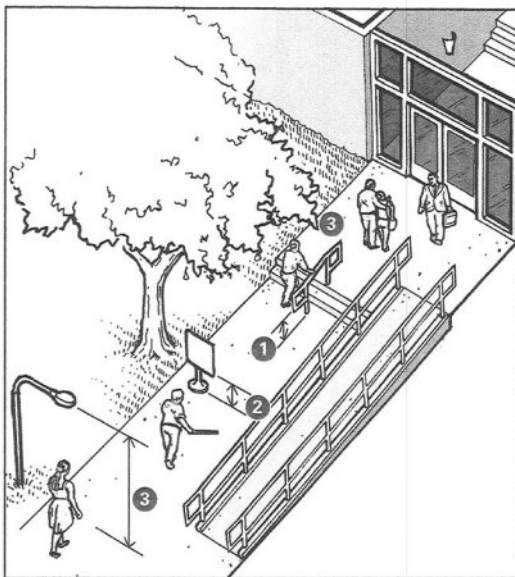

Gray Smith's Office

Architecture & Community Development
Expert Analysis & Testimony

Name of Polling Place: Chinese-American Community Center **County:** New Castle
FINDINGS AND RECOMMENDATIONS BASED ON ON-SITE SURVEY AND ADA REQUIREMENTS
Survey Performed by: Gray Smith AIA AICP
Survey Date: May 9, 2005

- 3. Pathway inside:** The long Corridor from the Kitchen entrance to the polling place room contains several obstacles that would be hazardous to sight-impaired persons.

Recommendation: At least on election day, remove all obstacles, that might impede sight-impaired persons.



- 4. Interior doors:** Current passage through the Multi-Purpose Room requires passage through a pair of doors to the Corridor. Each door when open allows for only 28 inches clear rather than 32 inches required.

Recommendation: If the doors continue to be used, prop both open continuously on election day.



Gray Smith's Office

Architecture & Community Development
Expert Analysis & Testimony

DELAWARE COMMISSIONER OF ELECTIONS POLLING PLACE ACCESSIBILITY RECOMMENDATIONS	
Name of Polling Place: Port Penn Volunteer Fire Company	County: New Castle
Address: 26 W. Market Street, Port Penn	
Contact Person(s) Assisting Survey: Barbara Lippincott	
Voting Area: Volunteer Fire Hall: Banquet Room	

FINDINGS AND RECOMMENDATIONS BASED ON ON-SITE SURVEY AND ADA REQUIREMENTS

Survey Performed by: Gray Smith AIA AICP
Survey Date: May 11, 2005

- 1. Parking:** Information obtained during the visit was that the parking lot was to be repaved in the near future. As such, re-stripping would be included. The current accessible spaces were not marked by signs.

Recommendation: In re-stripping, locate accessible parking spaces and one van-accessible space near to the entrance in accordance with the drawing below. Include upright signs at 5 feet high, with "van-accessible" designation and blue striping for accessible spaces and side aisles.

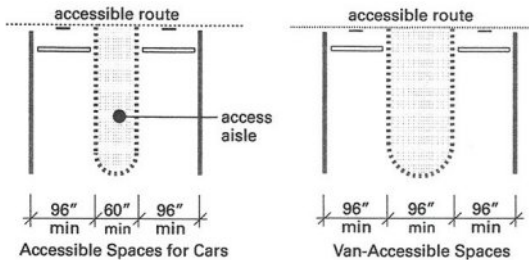

Gray Smith's Office

Architecture & Community Development
Expert Analysis & Testimony

Name of Polling Place: Port Penn Volunteer Fire Company **County:** New Castle
FINDINGS AND RECOMMENDATIONS BASED ON ON-SITE SURVEY AND ADA REQUIREMENTS
Survey Performed by: Gray Smith AIA AICP
Survey Date: May 11, 2005

2. **Entrance landing:** There are raised edges, greater than ½ inch, at the concrete entrance landing.

Recommendation: When repaving the parking lot, correct and even out the level change.

3. **Entrance door:** The push pressure of the entrance door measured 12 pounds.

Recommendation: Adjust or replace automatic door closer to achieve a maximum push pressure of 5 pounds.



Gray Smith's Office

Architecture & Community Development
Expert Analysis & Testimony

DELAWARE COMMISSIONER OF ELECTIONS POLLING PLACE ACCESSIBILITY RECOMMENDATIONS	
Name of Polling Place: Odessa Fire Hall	County: New Castle
Address: 304 Main Street, Odessa	
Contact Person(s) Assisting Survey: Barbara Lippincott	
Voting Area: Volunteer Fire Hall: Banquet Hall	

FINDINGS AND RECOMMENDATIONS BASED ON ON-SITE SURVEY AND ADA REQUIREMENTS

Survey Performed by: Gray Smith AIA AICP

Survey Date: May 11, 2005

- Parking:** There are no designated accessible parking spaces, such that Election personnel must install temporary accessible parking signs on the street near to the entrance.

Recommendation: Coordinate with the local Department of Streets to secure, design and designate at least 2 permanent, accessible, parallel, on-street parking spaces as indicated in the drawing below. One shall be van-accessible. Install upright signs at 5 feet high, including a "van-accessible" sign.

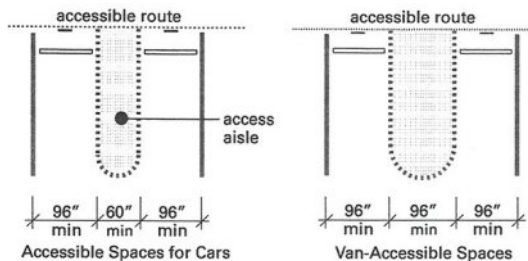

Gray Smith's Office

Architecture & Community Development
Expert Analysis & Testimony

Name of Polling Place: Odessa Fire Hall **County:** New Castle

FINDINGS AND RECOMMENDATIONS BASED ON ON-SITE SURVEY AND ADA REQUIREMENTS

Survey Performed by: Gray Smith AIA AICP

Survey Date: May 11, 2005

- 2. Entrance and inside doors:** Each of the doors in the 2 pairs did not allow for a clear opening of 32 inches.

Recommendation: As has been done on previous election days, the pairs of doors must be propped open continuously, or personnel must be available to open both doors in a pair to assist persons in wheelchairs.



Gray Smith's Office

Architecture & Community Development
Expert Analysis & Testimony

DELAWARE COMMISSIONER OF ELECTIONS POLLING PLACE ACCESSIBILITY RECOMMENDATIONS	
Name of Polling Place: Corbitt-Calloway Library	County: New Castle
Address: 2 nd & High Street, Odessa	
Contact Person(s) Assisting Survey: Barbara Lippincott	
Voting Area: Private Library: Reading Room	

FINDINGS AND RECOMMENDATIONS BASED ON ON-SITE SURVEY AND ADA REQUIREMENTS

Survey Performed by: Gray Smith AIA AICP
Survey Date: May 11, 2005

- Parking:** None of the parking spaces was designated for accessibility; however, on election day, temporary spaces are designated on the street in front of the library.

Recommendation: Coordinate with the local Department of Streets to secure, design and designate at least 2 permanent accessible on-street parking spaces, as indicated in the drawing below. One shall be van-accessible. Install upright signs at 5 feet high, including a "van-accessible" sign.

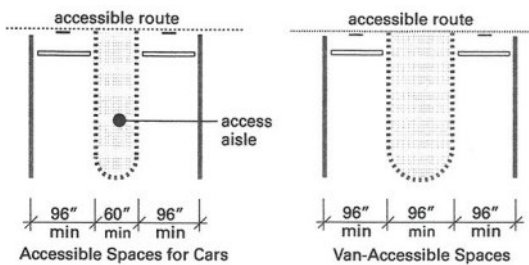

Gray Smith's Office

Architecture & Community Development
Expert Analysis & Testimony

Name of Polling Place: Corbitt-Calloway Library **County:** New Castle
FINDINGS AND RECOMMENDATIONS BASED ON ON-SITE SURVEY AND ADA REQUIREMENTS
Survey Performed by: Gray Smith AIA AICP
Survey Date: May 11, 2005

- 2. Entry walkway:** The portion of the brick-paver, public sidewalk in front of the facility entrance (a landing) has raised edges greater than 1/2 inch.

Recommendation: Remove and reset the brick-pavers on the two sides of the "landing" to raise them to the same level as the "landing" and eliminate the edges.

- 3. Entrance ramp:** Whereas the wood entrance ramp is suitable, the handrails on each side, constructed of 2 x 6's on flat, do not provide a graspable surface.

Recommendation: Supplement the existing railings with 2-inch diameter handrails and brackets. Include extensions at the upper and lower ends as in the drawing below.

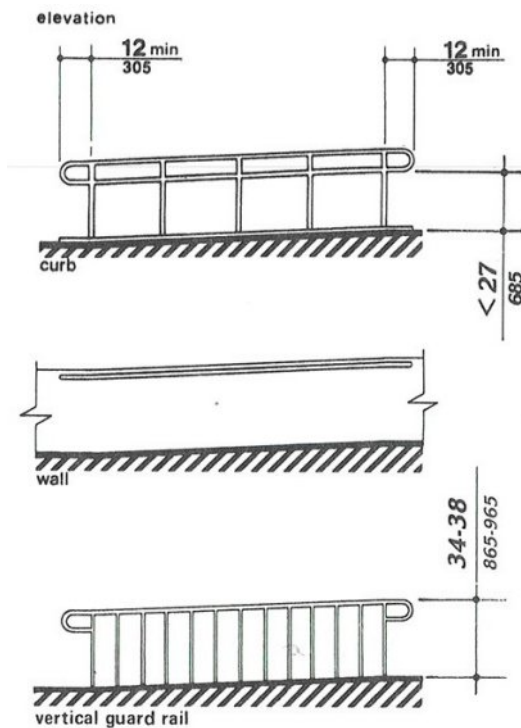

Gray Smith's Office

Architecture & Community Development
Expert Analysis & Testimony

Name of Polling Place: Corbitt-Calloway Library **County:** New Castle

FINDINGS AND RECOMMENDATIONS BASED ON ON-SITE SURVEY AND ADA REQUIREMENTS

Survey Performed by: Gray Smith AIA AICP

Survey Date: May 11, 2005

- 4. Interior doors:** Each pair of doors within the pathway to the polling place, is only 30 ½ inches clear when open.

Recommendation: On election day, keep both doors in the pair open continuously.



Gray Smith's Office

Architecture & Community Development
Expert Analysis & Testimony

DELAWARE COMMISSIONER OF ELECTIONS POLLING PLACE ACCESSIBILITY RECOMMENDATIONS	
Name of Polling Place: Blackbird Community Center	County: New Castle
Address: Blackbird Forest Road, Townsend	
Contact Person(s) Assisting Survey: Barbara Lippincott	
Voting Area: Community Center: Multi-Purpose Room	

FINDINGS AND RECOMMENDATIONS BASED ON ON-SITE SURVEY AND ADA REQUIREMENTS

Survey Performed by: Gray Smith AIA AICP
Survey Date: May 11, 2005

Note: Entry was not available to this facility during the visit.

- Parking:** There were designated accessible parking spaces; however, there were no side access aisles, no van-accessible space, and no upright signs.

Recommendation: Reconfigure and repaint the parking area in accordance with the drawing below. Include one van-accessible space and upright signs at 5 feet high, including a "van-accessible" sign.

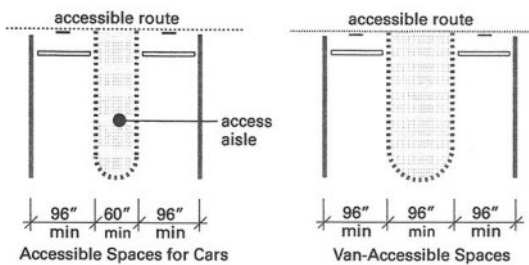

Gray Smith's Office

Architecture & Community Development
Expert Analysis & Testimony

Name of Polling Place: Blackbird Community Center **County:** New Castle
FINDINGS AND RECOMMENDATIONS BASED ON ON-SITE SURVEY AND ADA REQUIREMENTS

Survey Performed by: Gray Smith AIA AICP

Survey Date: May 11, 2005

2. **Entrance ramp:** The concrete entrance ramp had a wood railing on one side with a 2 x 4 flat top, which is not graspable. There was no handrail on one side of the ramp.

Recommendation: Install a 2-inch diameter handrail with brackets on the wall side of the ramp. Install a supplemental 2-inch diameter handrail and brackets onto the existing outside railing. Include extensions at the top and bottom of the ramp at 12 inches, as in the drawing below.

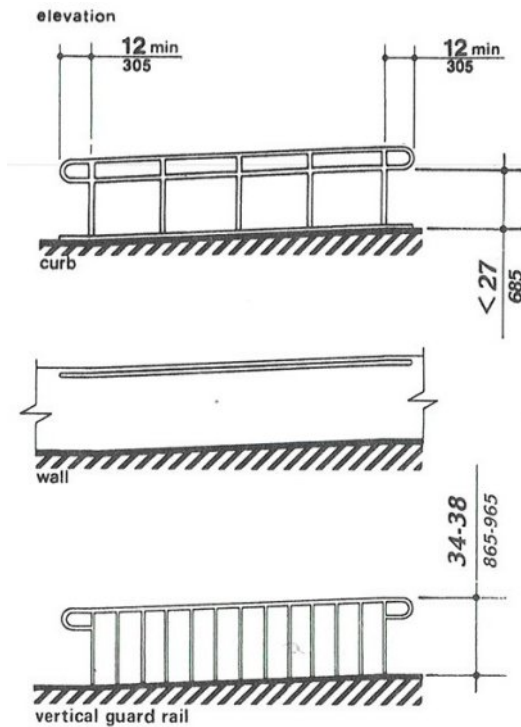

Gray Smith's Office

Architecture & Community Development
Expert Analysis & Testimony

Name of Polling Place: Blackbird Community Center **County:** New Castle
FINDINGS AND RECOMMENDATIONS BASED ON ON-SITE SURVEY AND ADA REQUIREMENTS

Survey Performed by: Gray Smith AIA AICP
Survey Date: May 11, 2005

3. Entrance door: The entrance door has doorknobs on both sides.

Recommendation: Replace the doorknobs with lever handles.



Gray Smith's Office

Architecture & Community Development
Expert Analysis & Testimony

DELAWARE COMMISSIONER OF ELECTIONS POLLING PLACE ACCESSIBILITY RECOMMENDATIONS	
Name of Polling Place: Freewill Baptist Church	County: New Castle
Address: 4519 S. Dupont Highway, Townsend	
Contact Person(s) Assisting Survey: Barbara Lippincott	
Voting Area: Church: Community Room	

FINDINGS AND RECOMMENDATIONS BASED ON ON-SITE SURVEY AND ADA REQUIREMENTS

Survey Performed by: Gray Smith AIA AICP
Survey Date: May 11, 2005

- 1. Parking:** Designated accessible parking spaces were provided with upright signs; however, there was no van-accessible space, and the surface painting was faded and confusing.

Recommendation: Reconfigure and repaint the accessible spaces to include one van-accessible space and upright "van-accessible" sign, as in the following drawing.

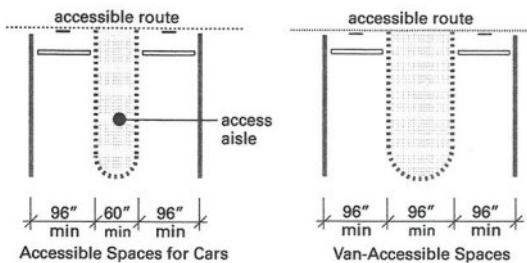

Gray Smith's Office

Architecture & Community Development
Expert Analysis & Testimony

Name of Polling Place: Freewill Baptist Church **County:** New Castle
FINDINGS AND RECOMMENDATIONS BASED ON ON-SITE SURVEY AND ADA REQUIREMENTS
Survey Performed by: Gray Smith AIA AICP
Survey Date: May 11, 2005

2. Entrance ramp: A long concrete ramp was provided; however, there was no edge curb to prevent wheelchair wheels from slipping off the edge; there was no handrail on one side; the handrail did not reach to the bottom of the ramp, and there were no handrail extensions at the top and bottom of the ramp.

Recommendation: Replace the existing handrail and install 2 new handrails on the ramp as indicated in the drawings below. Include edge protection and extensions.

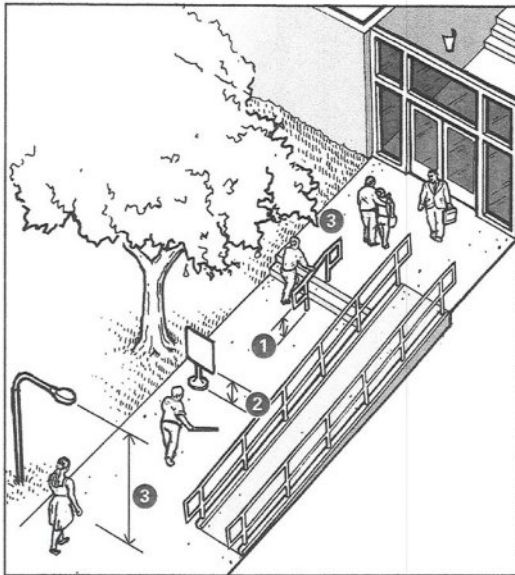

Gray Smith's Office

Architecture & Community Development
Expert Analysis & Testimony

Name of Polling Place: Freewill Baptist Church **County:** New Castle
FINDINGS AND RECOMMENDATIONS BASED ON ON-SITE SURVEY AND ADA REQUIREMENTS
Survey Performed by: Gray Smith AIA AICP
Survey Date: May 11, 2005

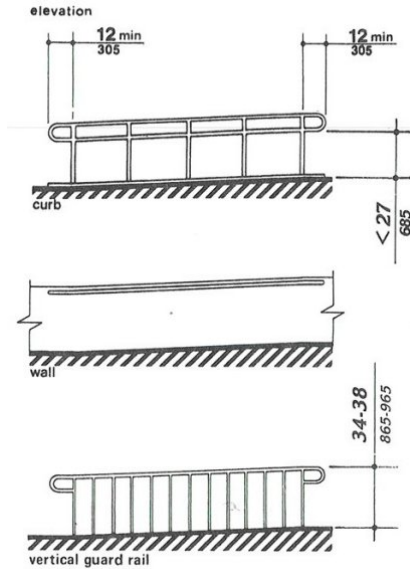

- 3. Entrance steps:** Steps at the entrance may be used by ambulatory disabled persons. The handrails on each side of the steps do not extend beyond the ends of the steps.

Recommendation: Replace the handrails with new handrails with 12-inch extensions at top and bottom as indicated in the following drawing.

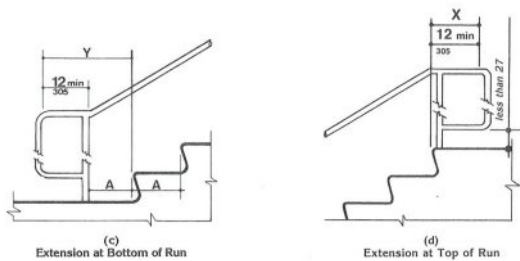

Gray Smith's Office

Architecture & Community Development
Expert Analysis & Testimony

DELAWARE COMMISSIONER OF ELECTIONS POLLING PLACE ACCESSIBILITY RECOMMENDATIONS	
Name of Polling Place: Wilmington Music School	County: New Castle
Address: 4101 N. Washington Street, Wilmington	
Contact Person(s) Assisting Survey: Cara Hartsky	
Voting Area: Private School	

FINDINGS AND RECOMMENDATIONS BASED ON ON-SITE SURVEY AND ADA REQUIREMENTS

Survey Performed by: Gray Smith AIA AICP

Survey Date: May 12, 2005

- Parking:** Although accessible parking spaces are provided near the main entrance to the School, there are none near the rear Courtyard entrance used to reach the polling place.

Recommendation: Convert and paint at least 2 parking spaces in the rear to accessible spaces with side access aisles in accordance with the drawing below. Make one space van-accessible. Add wall-mounted signs with one "van-accessible" sign.

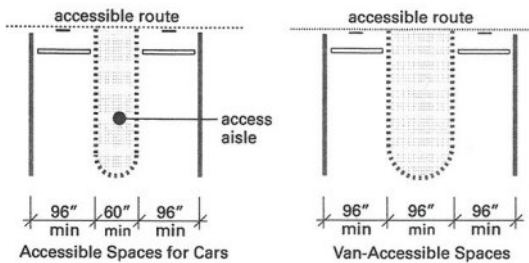

Gray Smith's Office

Architecture & Community Development
Expert Analysis & Testimony

Name of Polling Place: Wilmington Music School **County:** New Castle

FINDINGS AND RECOMMENDATIONS BASED ON ON-SITE SURVEY AND ADA REQUIREMENTS

Survey Performed by: Gray Smith AIA AICP

Survey Date: May 12, 2005

- 2. Walkway lighting:** The rear Courtyard entrance is inadequately lighted.

Recommendation: Install at least 2 floodlights to illuminate Courtyard.

- 3. Entrance doors:** The rear Courtyard entrance doors required a push pressure of 12 pounds to open.

Recommendation: Adjust or replace automatic door closer to assure a maximum of 5 pounds push pressure.



Gray Smith's Office

Architecture & Community Development
Expert Analysis & Testimony

DELAWARE COMMISSIONER OF ELECTIONS POLLING PLACE ACCESSIBILITY RECOMMENDATIONS	
Name of Polling Place: Police Athletic League	County: New Castle
Address: 3707 N. Market Street, Wilmington	
Contact Person(s) Assisting Survey: Cara Hartsky	
Voting Area: Police Athletic League: Multi-purpose Room	

FINDINGS AND RECOMMENDATIONS BASED ON ON-SITE SURVEY AND ADA REQUIREMENTS	
Survey Performed by: Gray Smith AIA AICP Survey Date: May 12, 2005	
<p>1. Entrance doors: The main entrance door had an automatic opening function that was not operable.</p> <p>Recommendation: Repair automatic opening function to assure operation on election day.</p>	

Gray Smith's Office

Architecture & Community Development
Expert Analysis & Testimony

DELAWARE COMMISSIONER OF ELECTIONS POLLING PLACE ACCESSIBILITY RECOMMENDATIONS	
Name of Polling Place: Crestview Apartments	County: New Castle
Address: 2700 N. Market Street, Wilmington	
Contact Person(s) Assisting Survey: Cara Hartsky	
Voting Area: Senior Apartments: Community Room	

FINDINGS AND RECOMMENDATIONS BASED ON ON-SITE SURVEY AND ADA REQUIREMENTS

Survey Performed by: Gray Smith AIA AICP
Survey Date: May 12, 2005

- 1. Parking:** There was no parking on the property. The parking lot for the tenants was across a street and contained accessible parking spaces.

Recommendation: On election day, designate 2 temporary parking spaces in the entrance driveway on each side of the curb cut in the entrance walkway. Restrict to voter use. Provide temporary signs: "Parking for Disabled Voters Only".



Gray Smith's Office

Architecture & Community Development
Expert Analysis & Testimony

DELAWARE COMMISSIONER OF ELECTIONS POLLING PLACE ACCESSIBILITY RECOMMENDATIONS	
Name of Polling Place: Kingswood Community Center	County: New Castle
Address: 2300 Bowers Street, Wilmington	
Contact Person(s) Assisting Survey: Cara Hartsky	
Voting Area: Community Center: Community Room	

FINDINGS AND RECOMMENDATIONS BASED ON ON-SITE SURVEY AND ADA REQUIREMENTS

Survey Performed by: Gray Smith AIA AICP
Survey Date: May 12, 2005

- 1. Parking:** There are no designated accessible spaces (except temporary on election day).

Recommendation: Designate and paint at least 2 parking spaces, including one van-accessible nearest to entrance, with side access aisles, in accordance with the drawing below. Provide upright signs at 5 feet high, with one "van-accessible" sign.

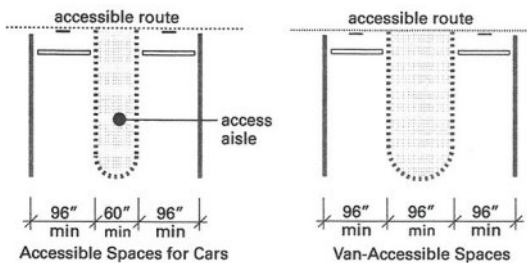

Gray Smith's Office

Architecture & Community Development
Expert Analysis & Testimony

Name of Polling Place: Kingswood Community Center **County:** New Castle
FINDINGS AND RECOMMENDATIONS BASED ON ON-SITE SURVEY AND ADA REQUIREMENTS
Survey Performed by: Gray Smith AIA AICP
Survey Date: May 12, 2005

2. Route to entrance: The only paved route to the entrance from the parking lot is hazardous through the parking lot entrance driveway and onto the public sidewalk.

Recommendation: Construct new accessible route walkways at the “nose” ends (with no curb) of the accessible parking spaces, and diagonally toward the entrance across the side yard. Connect the new walkway to the middle of the front entrance walkway.

Note: A sign posted on the site indicated a major renovation for the center. Coordination between Election Commission and the operator of the center is recommended, regarding accessible elements.



Gray Smith's Office

Architecture & Community Development
Expert Analysis & Testimony

Name of Polling Place: Kingswood Community Center **County:** New Castle

FINDINGS AND RECOMMENDATIONS BASED ON ON-SITE SURVEY AND ADA REQUIREMENTS

Survey Performed by: Gray Smith AIA AICP

Survey Date: May 12, 2005

- 3. Entrance doors:** The main entrance doors have a threshold with a vertical edge of over ½ inch. The doors require a push pressure of 10 pounds to open.

Recommendation: Replace the threshold with a wider, beveled, low-profile, aluminum threshold. Adjust or replace the automatic door closer to assure a maximum of 5 pounds push pressure.

- 4. Vestibule doors:** The interior Vestibule doors require a push pressure of 15 pounds to open.

Recommendation: Adjust or replace the automatic door closer to assure a maximum of 5 pounds push pressure.



Gray Smith's Office

Architecture & Community Development
Expert Analysis & Testimony

DELAWARE COMMISSIONER OF ELECTIONS POLLING PLACE ACCESSIBILITY RECOMMENDATIONS	
Name of Polling Place: Wilmington Senior Center	County: New Castle
Address: 1901 N. Market Street, Wilmington	
Contact Person(s) Assisting Survey: Cara Hartsky	
Voting Area: Senior Citizen Center: Multi-purpose Room	

FINDINGS AND RECOMMENDATIONS BASED ON ON-SITE SURVEY AND ADA REQUIREMENTS

Survey Performed by: Gray Smith AIA AICP
Survey Date: May 12, 2005

Parking: Only 2 accessible spaces are provided plus one temporary space on election day. There were no upright or wall-mounted signs.

Recommendation: A senior citizen center should have multiple accessible parking spaces for use by regular users, and voters on election day. Reconfigure and paint the surface to provide at least 2 accessible parking spaces with side access aisles and van-accessible space, in accordance with the drawing below. Include wall-mounted or upright signs at 5 feet high, with one "van-accessible" sign.

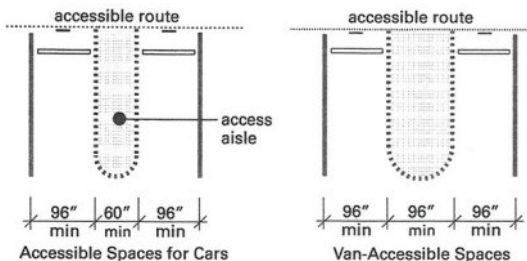

Gray Smith's Office

Architecture & Community Development
Expert Analysis & Testimony

DELAWARE COMMISSIONER OF ELECTIONS POLLING PLACE ACCESSIBILITY RECOMMENDATIONS	
Name of Polling Place: Baynard Apartments	County: New Castle
Address: 309 W. 18 th Street, Wilmington	
Contact Person(s) Assisting Survey: Cara Hartsky	
Voting Area: Senior Apartment Building: Community Room	

FINDINGS AND RECOMMENDATIONS BASED ON ON-SITE SURVEY AND ADA REQUIREMENTS

Survey Performed by: Gray Smith AIA AICP
Survey Date: May 12, 2005

- 1. Parking:** Parking is limited on the property, and the accessible spaces are deficient: without side access aisles and paint is worn away. There is one permanent, on-street curbside parking space marked as accessible.

Recommendation: Coordinate with local Department of Streets to designate an additional, on-street curbside, accessible parking space with upright sign. On election day, preserve the 2 spaces for voters with temporary signs. Replace upright sign with DE DOT approved sign.

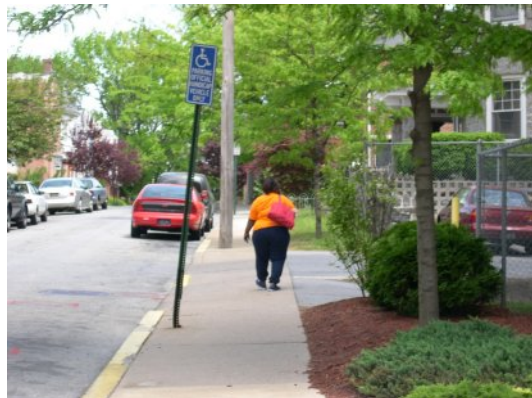

Gray Smith's Office

Architecture & Community Development
Expert Analysis & Testimony

DELAWARE COMMISSIONER OF ELECTIONS POLLING PLACE ACCESSIBILITY RECOMMENDATIONS	
Name of Polling Place: The Park View	County: New Castle
Address: 1800 N. Broom Street, Wilmington	
Contact Person(s) Assisting Survey: Cara Hartsky	
Voting Area: Senior Citizen Apartments: Community Room	

FINDINGS AND RECOMMENDATIONS BASED ON ON-SITE SURVEY AND ADA REQUIREMENTS

Survey Performed by: Gray Smith AIA AICP
Survey Date: May 12, 2005

- 1. Parking:** Accessible parking spaces are provided in a rear parking lot; however, the paint is worn away. They are also remote from the entrance, which must be reached by a very long ramped walkway.

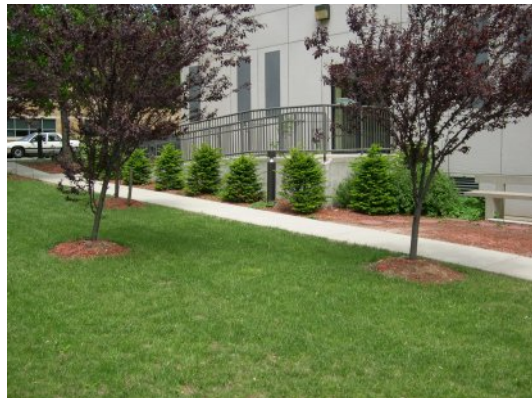

Recommendation: Coordinate with the local Department of Streets to secure permanent (or temporary) designation of 2 accessible parking spaces on North Broom Street near the main building entrance. Secure upright or temporary signs for election day.



Gray Smith's Office

Architecture & Community Development
Expert Analysis & Testimony

DELAWARE COMMISSIONER OF ELECTIONS POLLING PLACE ACCESSIBILITY RECOMMENDATIONS	
Name of Polling Place: Grace Methodist Church	County: New Castle
Address: 900 N. Washington Street, Wilmington	
Contact Person(s) Assisting Survey: Cara Hartsky	
Voting Area: Church: Fellowship Hall	

FINDINGS AND RECOMMENDATIONS BASED ON ON-SITE SURVEY AND ADA REQUIREMENTS	
Survey Performed by: Gray Smith AIA AICP Survey Date: May 12, 2005	
<p>Parking: One of the accessible parking spaces was missing an upright sign.</p> <p>Recommendation: Install an upright sign.</p> 	

Gray Smith's Office

Architecture & Community Development
Expert Analysis & Testimony

DELAWARE COMMISSIONER OF ELECTIONS POLLING PLACE ACCESSIBILITY RECOMMENDATIONS	
Name of Polling Place: Hicks Anderson Community Center	County: New Castle
Address: 501 N. Madison Street, Wilmington	
Contact Person(s) Assisting Survey: Cara Hartsky	
Voting Area: Community Center: small Community Room	

FINDINGS AND RECOMMENDATIONS BASED ON ON-SITE SURVEY AND ADA REQUIREMENTS

Survey Performed by: Gray Smith AIA AICP
Survey Date: May 12, 2005

- Parking:** The entrance to the polling place is in the rear lower floor, not the main building entrance to the upper floor. The rear parking lot is in poor condition. Accessible parking spaces are provided; however, the paint is worn away and a large, built-up curb ramp is incorrectly formed.

Recommendation: Remove the built-up curb ramp. Repair the parking surface and paint at least 2 new accessible spaces in accordance with the drawing below, including one van-accessible space. Install upright and wall-mounted signs at 5 feet high, and one "van-accessible" sign.

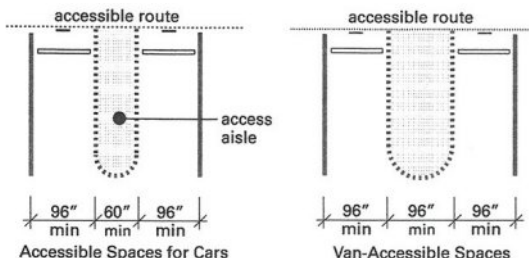

Gray Smith's Office

Architecture & Community Development
Expert Analysis & Testimony

Name of Polling Place: Hicks Anderson Community Center **County:** New Castle
FINDINGS AND RECOMMENDATIONS BASED ON ON-SITE SURVEY AND ADA REQUIREMENTS
Survey Performed by: Gray Smith AIA AICP
Survey Date: May 12, 2005

- 2. **Route to entrance:** Concrete walkway apron is cracked and spalled.

Recommendation: Remove and repave concrete walkway apron with new internal curb ramp as indicated in drawing below. Paint parking surface in front of curb ramp with "no parking" diagonal stripes.

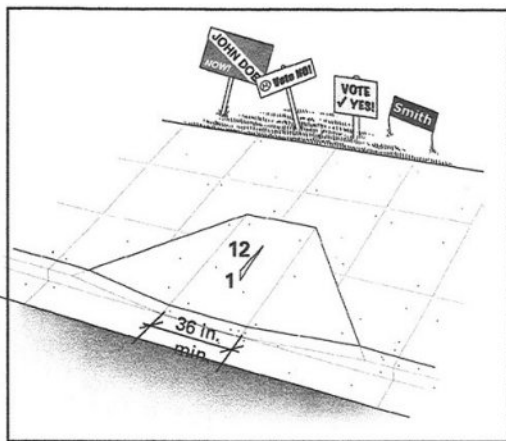

Curb ramp showing minimum 36 inch width for ramp section and 1:12 slope on ramp section.



Gray Smith's Office

Architecture & Community Development
Expert Analysis & Testimony

DELAWARE COMMISSIONER OF ELECTIONS POLLING PLACE ACCESSIBILITY RECOMMENDATIONS	
Name of Polling Place: Quaker Hill Place Apartments	County: New Castle
Address: 200 N. Washington Street, Wilmington	
Contact Person(s) Assisting Survey: Cara Hartsky	
Voting Area:	

FINDINGS AND RECOMMENDATIONS BASED ON ON-SITE SURVEY AND ADA REQUIREMENTS
Survey Performed by: Gray Smith AIA AICP
Survey Date: May 12, 2005

- Parking:** Two “reserved” accessible parking spaces are provided near the entrance to the facility; however, there is no van-accessible space. Other parking spaces at this location are “15-minute” and “reserved” spaces.

Recommendation: Reconfigure and repaint accessible spaces to make 2 van-accessible spaces with 96 inches side access aisle as indicated in the drawing below. Add “van-accessible” sign on upright sign. On election day designate these 2 spaces for voters only and make special arrangements for the 2 vehicle owners for whom the spaces are reserved.

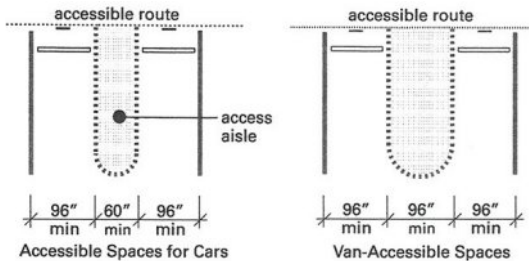

Gray Smith's Office

Architecture & Community Development
Expert Analysis & Testimony

Name of Polling Place: Quaker Hill Place Apartments **County:** New Castle
FINDINGS AND RECOMMENDATIONS BASED ON ON-SITE SURVEY AND ADA REQUIREMENTS
Survey Performed by: Gray Smith AIA AICP
Survey Date: May 12, 2005

2. **Curb ramp:** The concrete curb ramp between the driveway and the building entrance has flared sides that are excessively steep and hazardous.

Recommendation: Remove and rebuild curb ramp in accordance with drawing below.

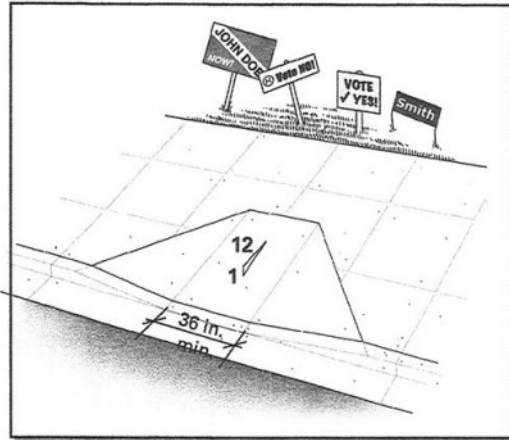

Curb ramp showing minimum 36 inch width for ramp section and 1:12 slope on ramp section.



Gray Smith's Office

Architecture & Community Development
Expert Analysis & Testimony

DELAWARE COMMISSIONER OF ELECTIONS POLLING PLACE ACCESSIBILITY RECOMMENDATIONS	
Name of Polling Place: Henrietta Johnson Medical Center	
County: New Castle	
Address: 601 New Castle Avenue, Wilmington	
Contact Person(s) Assisting Survey: Cara Hartsky	
Voting Area: Health Center: Meeting Room	

FINDINGS AND RECOMMENDATIONS BASED ON ON-SITE SURVEY AND ADA REQUIREMENTS	
Survey Performed by: Gray Smith AIA AICP Survey Date: May 12, 2005	
<p>Parking: Accessible parking is provided including 2 van-accessible spaces; however, the van-accessible spaces do not have “van-accessible” signs.</p> <p>Recommendation: Install 2 “van-accessible” signs.</p>	

Gray Smith's Office

Architecture & Community Development
Expert Analysis & Testimony

DELAWARE COMMISSIONER OF ELECTIONS POLLING PLACE ACCESSIBILITY RECOMMENDATIONS	
Name of Polling Place: Wilmington Friends School	County: New Castle
Address: 101 School Road, Wilmington	
Contact Person(s) Assisting Survey: Cara Hartsky	
Voting Area: Private School: Gymnasium	

FINDINGS AND RECOMMENDATIONS BASED ON ON-SITE SURVEY AND ADA REQUIREMENTS	
Survey Performed by: Gray Smith AIA AICP Survey Date: May 12, 2005	
<p>Parking: Accessible parking is provided including 2 van-accessible spaces; however, the van-accessible spaces do not have “van-accessible” signs. Surface paint is wearing away.</p> <p>Recommendation: Install 2 “van-accessible” signs. Repaint surface paint.</p>	

Gray Smith's Office

Architecture & Community Development
Expert Analysis & Testimony

DELAWARE COMMISSIONER OF ELECTIONS POLLING PLACE ACCESSIBILITY RECOMMENDATIONS	
Name of Polling Place: Lutheran Church/Good Sheperd	County: New Castle
Address: 1530 Foulk Road, Wilmington	
Contact Person(s) Assisting Survey: Cara Hartsky	
Voting Area: Church: Fellowship Hall	

FINDINGS AND RECOMMENDATIONS BASED ON ON-SITE SURVEY AND ADA REQUIREMENTS

Survey Performed by: Gray Smith AIA AICP

Survey Date: May 12, 2005

- 1. Parking:** Accessible parking is provided including 2 van-accessible spaces; however, there are no upright signs, and no van-accessible spaces do not have "van-accessible" signs.

Recommendation: Install upright signs at 5 feet high and, 2 "van-accessible" signs.



- 2. Entry ramp:** A concrete entry ramp is provided; however, there are no handrails, there is a hazardous edge drop-off and one construction joint has a raised edge over 1/2 inch high.

Recommendation: Install handrails on both sides of the ramp with curb protection as indicated in the following drawing. Repair raised edge with cut out and epoxy cement.



Gray Smith's Office

Architecture & Community Development
Expert Analysis & Testimony

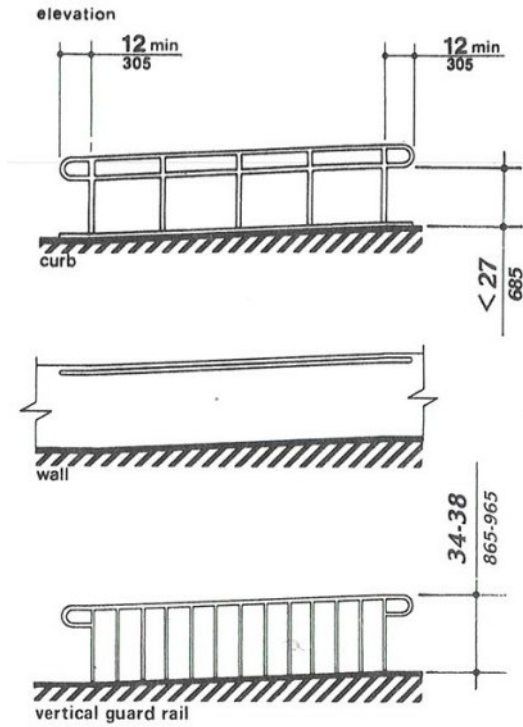

Name of Polling Place: Lutheran Church/Good Sheperd **County:** New Castle
FINDINGS AND RECOMMENDATIONS BASED ON ON-SITE SURVEY AND ADA REQUIREMENTS
Survey Performed by: Gray Smith AIA AICP
Survey Date: May 12, 2005



Gray Smith's Office

Architecture & Community Development
Expert Analysis & Testimony

DELAWARE COMMISSIONER OF ELECTIONS POLLING PLACE ACCESSIBILITY RECOMMENDATIONS	
Name of Polling Place: First Unitarian Church	County: New Castle
Address: 730 Halstead Road, Wilmington	
Contact Person(s) Assisting Survey: Cara Hartsky	
Voting Area: Church: Multi-purpose Room	

FINDINGS AND RECOMMENDATIONS BASED ON ON-SITE SURVEY AND ADA REQUIREMENTS	
<p>Survey Performed by: Gray Smith AIA AICP Survey Date: May 12, 2005</p>	
<p>1. Parking: Parking closest to the polling place entrance is temporary, on the street during election day.</p> <p>Recommendation: Coordinate with local Department of Streets to designate 2 permanent on-street accessible parking spaces with upright signs and surface painting. Include one van-accessible space.</p> <div style="text-align: center;">  </div> <p>2. Entrance ramp: The long entrance ramp has one handrail that does not extend at the top end.</p> <p>Recommendation: Install a second handrail similar to existing, and extend the top ends of both 12 inches beyond the ramp as in drawing below.</p>	 

Gray Smith's Office

Architecture & Community Development
Expert Analysis & Testimony

Name of Polling Place: First Unitarian Church **County:** New Castle
FINDINGS AND RECOMMENDATIONS BASED ON ON-SITE SURVEY AND ADA REQUIREMENTS
Survey Performed by: Gray Smith AIA AICP
Survey Date: May 12, 2005

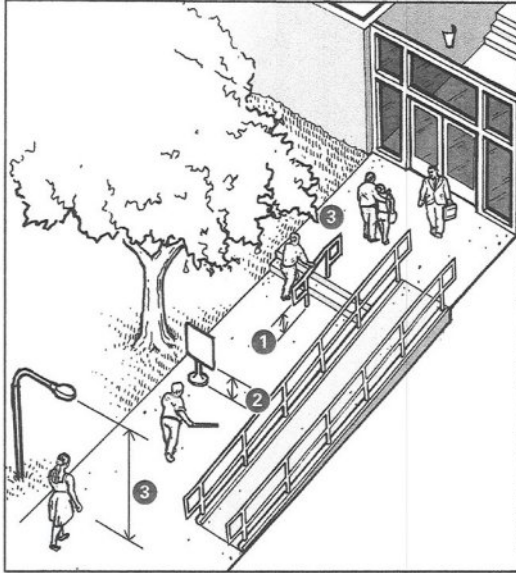

- 3. Entrance doors:** The main entrance door pair when opened on one side, has only 30 ½ inches clear, rather than 32 inches. The push pressure to the door was 15 pounds.

Recommendation: On election day, have personnel available to open both doors for wheelchairs. Adjust or replace automatic door closers to assure a maximum of 5 pounds push pressure.

- 4. Interior doors:** Each of the pair of interior doors to the polling place have only 30 inches clear when open.

Recommendation: On election day, prop open both doors continuously.



Gray Smith's Office

Architecture & Community Development
Expert Analysis & Testimony

DELAWARE COMMISSIONER OF ELECTIONS POLLING PLACE ACCESSIBILITY RECOMMENDATIONS	
Name of Polling Place: Mary Campbell Center	
County: New Castle	
Address: 4641 Weldin Road, Wilmington	
Contact Person(s) Assisting Survey: Cara Hartsky	
Voting Area: Disabled Adults Home: Community Room	

FINDINGS AND RECOMMENDATIONS BASED ON ON-SITE SURVEY AND ADA REQUIREMENTS	
Survey Performed by: Gray Smith AIA AICP Survey Date: May 12, 2005	
<p>Parking: There is ample accessible parking including van-accessible spaces; however, the van-accessible spaces do not have “van-accessible” signs, and the surface paint is wearing away.</p> <p>Recommendation: Install “van-accessible” signs, and repaint the surface striping.</p>	

Gray Smith's Office

Architecture & Community Development
Expert Analysis & Testimony

DELAWARE COMMISSIONER OF ELECTIONS POLLING PLACE ACCESSIBILITY RECOMMENDATIONS	
Name of Polling Place: Trinity Presbyterian Church	County: New Castle
Address: 1120 Darley Road, Wilmington	
Contact Person(s) Assisting Survey: Cara Hartsky	
Voting Area: Church: Multi-purpose Room ("Wysham Room")	

FINDINGS AND RECOMMENDATIONS BASED ON ON-SITE SURVEY AND ADA REQUIREMENTS
Survey Performed by: Gray Smith AIA AICP
Survey Date: June 10, 2005

1. Parking: Accessible parking spaces are remote from the polling place entrance. On election day, temporary spaces are marked and reserved for accessible voter parking.

Recommendation: Convert the temporary parking spaces to accessible spaces, one of which is van-accessible. Surface paint and include side access aisles, in accordance with the drawing below. Install upright signs at 5 feet high with one "van-accessible" sign.

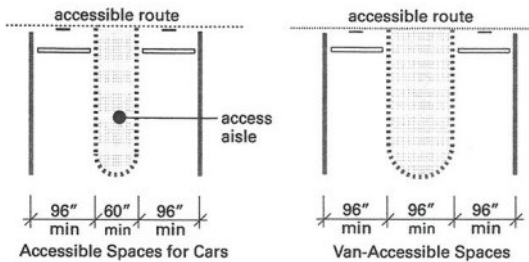

Gray Smith's Office

Architecture & Community Development
Expert Analysis & Testimony

Name of Polling Place: Trinity Presbyterian Church **County:** New Castle
FINDINGS AND RECOMMENDATIONS BASED ON ON-SITE SURVEY AND ADA REQUIREMENTS

Survey Performed by: Gray Smith AIA AICP

Survey Date: June 10, 2005

- 2. Entrance doors:** There is a 1 ½ inch raised edge, higher than ½ inch, at the transition between the exterior landing and the driveway surface. The operable door requires 10 pounds push pressure to open.

Recommendation: Cut and patch driveway asphalt to raise surface to slope up and transition evenly at concrete landing. Adjust or replace automatic door closer to assure a maximum of 5 pounds push pressure.



Gray Smith's Office

Architecture & Community Development
Expert Analysis & Testimony

DELAWARE COMMISSIONER OF ELECTIONS POLLING PLACE ACCESSIBILITY RECOMMENDATIONS	
Name of Polling Place: Gild Hall – Arden Club	County: New Castle
Address: 2126 The Highway, Wilmington	
Contact Person(s) Assisting Survey: Cara Hartsky	
Voting Area: Neighborhood Community Center/Club	

FINDINGS AND RECOMMENDATIONS BASED ON ON-SITE SURVEY AND ADA REQUIREMENTS

Survey Performed by: Gray Smith AIA AICP

Survey Date: June 10, 2005

- Parking:** There are no designated accessible parking spaces in the ample parking lot.

Recommendation: Designate and paint parking spaces nearest to the entrance as accessible, including one van-accessible space, as indicated in the following drawing. Provide upright signs at 5 feet high and a "van-accessible" sign.

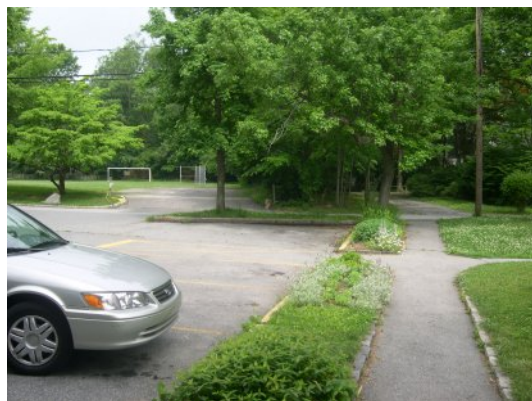
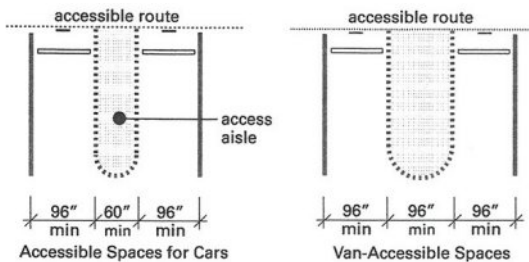

Gray Smith's Office

Architecture & Community Development
Expert Analysis & Testimony

Name of Polling Place: Gild Hall – Arden Club **County:** New Castle
FINDINGS AND RECOMMENDATIONS BASED ON ON-SITE SURVEY AND ADA REQUIREMENTS
Survey Performed by: Gray Smith AIA AICP
Survey Date: June 10, 2005

- 2. Front drop-off area:** A vehicle drop-off area is available on the street near the building entrance; however, there is no curb ramp.

Recommendation: Construct a curb ramp within the wide walkway in front of the entrance area, in accordance with the drawing below.

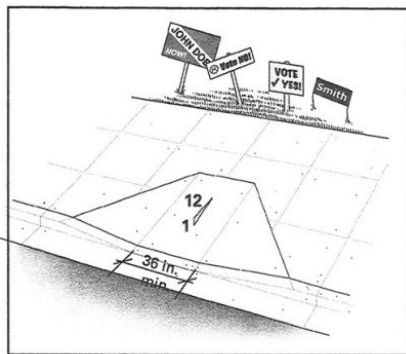

Curb ramp showing minimum 36 inch width for ramp section and 1:12 slope on ramp section.

- 3. Ramp from parking to entrance:** The ramped walkway does not have handrails.

Recommendation: Install handrails as indicated in the drawing below.

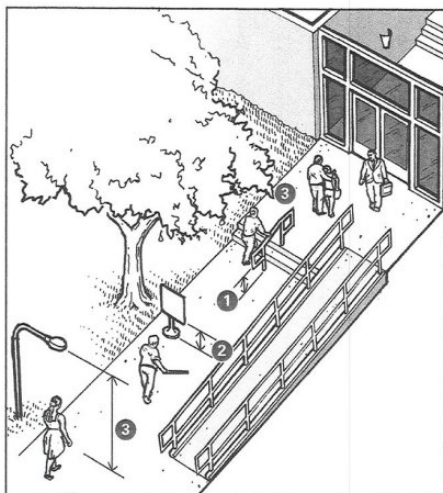

Gray Smith's Office

Architecture & Community Development
Expert Analysis & Testimony

Name of Polling Place: Gild Hall – Arden Club **County:** New Castle

FINDINGS AND RECOMMENDATIONS BASED ON ON-SITE SURVEY AND ADA REQUIREMENTS

Survey Performed by: Gray Smith AIA AICP

Survey Date: June 10, 2005

- 4. Entrance doors:** When open, each of the pair of doors provides only 28 inches clear, rather than 32 inches. The doors required 10 pounds push pressure to open.

Recommendation: Provide personnel at the doors to open both for wheelchairs on election day. Adjust or replace automatic door opener to assure a maximum 5 pounds push pressure.



Gray Smith's Office

Architecture & Community Development
Expert Analysis & Testimony

DELAWARE COMMISSIONER OF ELECTIONS POLLING PLACE ACCESSIBILITY RECOMMENDATIONS	
Name of Polling Place: Forwood Manor	County: New Castle
Address: 1912 Marsh Road, Wilmington	
Contact Person(s) Assisting Survey: Cara Hartsky	
Voting Area: Senior Citizen Housing: Sitting Room	

FINDINGS AND RECOMMENDATIONS BASED ON ON-SITE SURVEY AND ADA REQUIREMENTS
Survey Performed by: Gray Smith AIA AICP
Survey Date: June 10, 2005

- Parking:** Some parking spaces are designated as accessible with surface symbols, however, the surface paint is wearing away, there are no side access aisles, there are no upright signs, there are no van-accessible spaces and parked vehicles block adjacent curb ramps.

Recommendation: Reconfigure and repaint accessible parking areas to provide side access aisles, one van-accessible space, as indicated in the drawing below. Provide upright signs at 5 feet high and "van-accessible" sign.

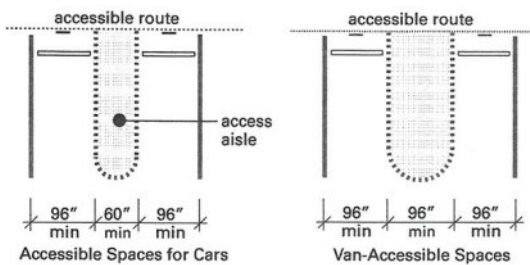

Gray Smith's Office

Architecture & Community Development
Expert Analysis & Testimony

Name of Polling Place: Forwood Manor County: New Castle

FINDINGS AND RECOMMENDATIONS BASED ON ON-SITE SURVEY AND ADA REQUIREMENTS

Survey Performed by: Gray Smith AIA AICP

Survey Date: June 10, 2005



2. **Curb ramps:** There are several poorly placed curb ramps (blocked by parked vehicles in parking spaces); also they have flared sides that are too steep.

Recommendation: If not adjacent to a side access aisle in the reconfigured accessible parking spaces (see above), relocate and construct new curb ramps in accordance with the following drawing.

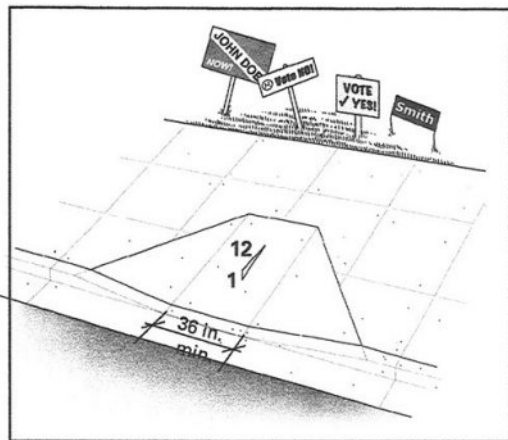

Curb ramp showing minimum 36 inch width for ramp section and 1:12 slope on ramp section.

Name of Polling Place: Forwood Manor **County:** New Castle
FINDINGS AND RECOMMENDATIONS BASED ON ON-SITE SURVEY AND ADA REQUIREMENTS
Survey Performed by: Gray Smith AIA AICP
Survey Date: June 10, 2005

3. Route to entrance: A tree overhangs low within the walkway from the parking area.

Recommendation: Trim back the tree to higher than 80 inches.



Gray Smith's Office

Architecture & Community Development
Expert Analysis & Testimony

DELAWARE COMMISSIONER OF ELECTIONS POLLING PLACE ACCESSIBILITY RECOMMENDATIONS	
Name of Polling Place: Shipley Manor	County: New Castle
Address: 2723 Shipley Road, Wilmington	
Contact Person(s) Assisting Survey: Cara Hartsky	
Voting Area: Senior Living Residence: Community Room	

FINDINGS AND RECOMMENDATIONS BASED ON ON-SITE SURVEY AND ADA REQUIREMENTS

Survey Performed by: Gray Smith AIA AICP

Survey Date: June 10, 2005

- 1. Parking:** Accessible parking is provided; however, there are only 2 spaces for the entire complex, there are no upright signs and no "van-accessible" sign for the van-accessible space.

Recommendation: On election day, designate 2 temporary parking spaces on the driveway next to the building entrance reserved for disabled voters. It is also recommended that the facility owner investigate the parking requirements of the federal *Fair Housing Act*.



Gray Smith's Office

Architecture & Community Development
Expert Analysis & Testimony

Name of Polling Place: Shipley Manor **County:** New Castle

FINDINGS AND RECOMMENDATIONS BASED ON ON-SITE SURVEY AND ADA REQUIREMENTS

Survey Performed by: Gray Smith AIA AICP

Survey Date: June 10, 2005

- 2. Route to entrance:** There is a raised edge, over ½ inch high, at the transition between the asphalt driveway and concrete entry walkway.

Recommendation: Cut out and build up with a patch of asphalt adjacent to the concrete walkway edge to provide an even transition.

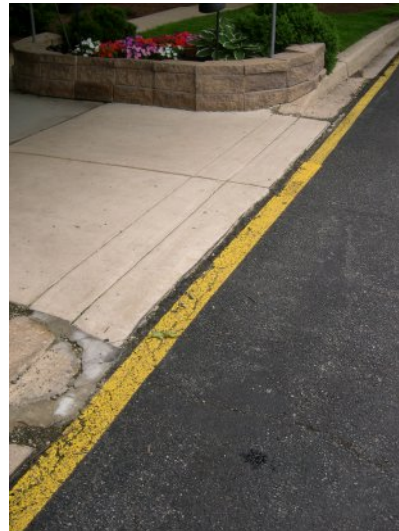

Gray Smith's Office

Architecture & Community Development
Expert Analysis & Testimony

DELAWARE COMMISSIONER OF ELECTIONS POLLING PLACE ACCESSIBILITY RECOMMENDATIONS	
Name of Polling Place: Brandywine Hundred Fire Hall	County: New Castle
Address: 1006 Brandywine Road, Wilmington	
Contact Person(s) Assisting Survey: Cara Hartsky	
Voting Area: Volunteer Fire Hall: Engine Room	

FINDINGS AND RECOMMENDATIONS BASED ON ON-SITE SURVEY AND ADA REQUIREMENTS

Survey Performed by: Gray Smith AIA AICP

Survey Date: June 10, 2005

- 1. Parking:** Accessible parking is provided; however, there are no upright signs, and one space was blocked by a portable sign.

Recommendation: Move portable sign. Install upright signs at 5 feet high, one with "van-accessible" sign. Install wheelstops to prevent vehicle contact with signs.



Gray Smith's Office

Architecture & Community Development
Expert Analysis & Testimony

DELAWARE COMMISSIONER OF ELECTIONS POLLING PLACE ACCESSIBILITY RECOMMENDATIONS	
Name of Polling Place: Hillcrest-Bellefonte Methodist Church	County: New Castle
Address: 400 Hillcrest Avenue, Wilmington	
Contact Person(s) Assisting Survey: Cara Hartsky	
Voting Area: Church	

FINDINGS AND RECOMMENDATIONS BASED ON ON-SITE SURVEY AND ADA REQUIREMENTS
Survey Performed by: Gray Smith AIA AICP
Survey Date: June 10, 2005

1. Parking: The accessible parking spaces are located remotely at the top of a long sloped parking lot. There are no accessible parking spaces near the entrance to the polling place.

Recommendation: Reconfigure and paint several parking spaces near the polling place entrance, with side access aisles and one van-accessible space, in accordance with the drawing below. Include upright signs at 5 feet high, with a "van-accessible" sign.

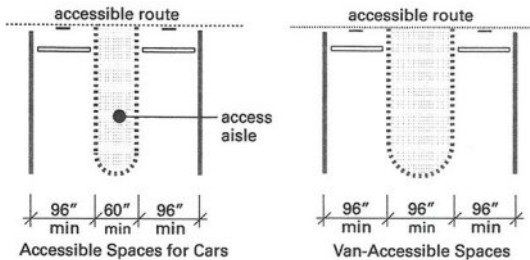

Gray Smith's Office

Architecture & Community Development
Expert Analysis & Testimony

Name of Polling Place: Hillcrest-Bellefonte Methodist Church **County:** New Castle
FINDINGS AND RECOMMENDATIONS BASED ON ON-SITE SURVEY AND ADA REQUIREMENTS
Survey Performed by: Gray Smith AIA AICP
Survey Date: June 10, 2005

- 2. Entrance door:** The entrance door is less than 32 inches clear when open, has a 1-inch high edge at the threshold, and has doorknobs.

Recommendation: Replace the wider emergency exit door at the end of the same exitway/ramped enclosure with a new door with a glass panel, lever hardware, low-profile aluminum threshold and an automatic door closer with a maximum 5 pounds push pressure to open (open out). Use this door for entrance and exit.

- 3. Lighting:** There were no nearby exterior light fixtures.

Recommendation: Install floodlighting overhead and wall-mounted fixtures adjacent to the 2 entrance/exit doors.



Gray Smith's Office

Architecture & Community Development
Expert Analysis & Testimony

Name of Polling Place: Hillcrest-Bellefonte Methodist Church **County:** New Castle
FINDINGS AND RECOMMENDATIONS BASED ON ON-SITE SURVEY AND ADA REQUIREMENTS
Survey Performed by: Gray Smith AIA AICP
Survey Date: June 10, 2005



4. Interior ramp: The interior ramp has handrails; however, one handrail is bent down and generally only 26 to 27 inches high, in lieu of 32 inches.

Recommendation: Raise existing handrail to 32 inches high throughout length. Add several wall brackets to stabilize from dipping.



Gray Smith's Office

Architecture & Community Development
Expert Analysis & Testimony

DELAWARE COMMISSIONER OF ELECTIONS POLLING PLACE ACCESSIBILITY RECOMMENDATIONS	
Name of Polling Place: St. David's Episcopal Church	County: New Castle
Address: 2320 Grubb Road, Wilmington	
Contact Person(s) Assisting Survey: Cara Hartsky	
Voting Area: Church: Day School	

FINDINGS AND RECOMMENDATIONS BASED ON ON-SITE SURVEY AND ADA REQUIREMENTS	
Survey Performed by: Gray Smith AIA AICP Survey Date: June 28, 2005	
<p>Entrance doors: The push pressure of the entrance door was 15 pounds to open.</p> <p>Recommendation: Adjust or replace automatic door closer to assure a maximum push pressure of 5 pounds</p>	

Gray Smith's Office

Architecture & Community Development
Expert Analysis & Testimony

DELAWARE COMMISSIONER OF ELECTIONS POLLING PLACE ACCESSIBILITY RECOMMENDATIONS	
Name of Polling Place: Emmanuel Presbyterian Church	County: New Castle
Address: 1006 Wilson Road, Wilmington	
Contact Person(s) Assisting Survey: Cara Hartsky	
Voting Area: Church: Fellowship Hall	

FINDINGS AND RECOMMENDATIONS BASED ON ON-SITE SURVEY AND ADA REQUIREMENTS	
Survey Performed by: Gray Smith AIA AICP Survey Date: June 28, 2005	
<p>Note: Visit to the interior of this facility was not possible during this visit.</p> <p>Parking: Accessible parking spaces are provided; however, there are no upright signs.</p> <p>Recommendation: Install upright signs 5 feet high at each accessible parking space, including "van-accessible" signs at van-accessible spaces.</p>	 



Gray Smith's Office

Architecture & Community Development
Expert Analysis & Testimony

DELAWARE COMMISSIONER OF ELECTIONS POLLING PLACE ACCESSIBILITY RECOMMENDATIONS	
Name of Polling Place: Concord Presbyterian Church	County: New Castle
Address: 1800 Fairfax Boulevard, Wilmington	
Contact Person(s) Assisting Survey: Cara Hartsky	
Voting Area: Church: Gymnasium	

FINDINGS AND RECOMMENDATIONS BASED ON ON-SITE SURVEY AND ADA REQUIREMENTS

Survey Performed by: Gray Smith AIA AICP
Survey Date: June 28, 2005

- Parking:** Parking spaces marked for disabled did not have side access aisles, and there were no van-accessible spaces. The paint was worn away and the upright signs were too low.

Recommendation: Reconfigure and repaint the parking area to include at least 3 accessible parking spaces, one of which is van-accessible in accordance with the drawing below. Provide upright signs at 5 feet high and include "van-accessible" signs.

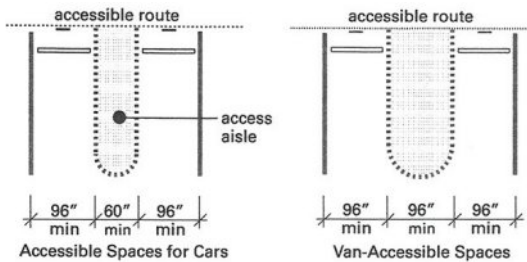

Gray Smith's Office

Architecture & Community Development
Expert Analysis & Testimony

Name of Polling Place: Concord Presbyterian Church **County:** New Castle
FINDINGS AND RECOMMENDATIONS BASED ON ON-SITE SURVEY AND ADA REQUIREMENTS
Survey Performed by: Gray Smith AIA AICP
Survey Date: June 28, 2005

2. Route to building: The accessible route is long and difficult distance with several defects.

- large trash dumpster in pathway;
- cracked and bumpy places in the concrete walkway;
- a difficult-to-open gate;
- wood chips scattered on the walkway.

Recommendation: Improve the alternative route as follows:

- repave and enlarge to 48 inches the concrete walkway from the parking area to the polling place entrance doors;
- relocate trash dumpster to another area of the parking lot;
- replace gate hardware with lever handles or push/pull hardware and a spring closer;
- assure removal of wood chips from walkway on election day;
- add a sign at the main entrance directing to the accessible entrance.
- add permanent signage: "Accessible Entry" with arrows along route, in several locations.



Gray Smith's Office

Architecture & Community Development
Expert Analysis & Testimony

Name of Polling Place: Concord Presbyterian Church **County:** New Castle
FINDINGS AND RECOMMENDATIONS BASED ON ON-SITE SURVEY AND ADA REQUIREMENTS
Survey Performed by: Gray Smith AIA AICP
Survey Date: June 28, 2005

- 3. Entrance doors:** Operable entrance door requires 25 pounds push pressure to open, swings open out as an obstruction to the walkway and has a threshold with a raised edge higher than ½ inch.

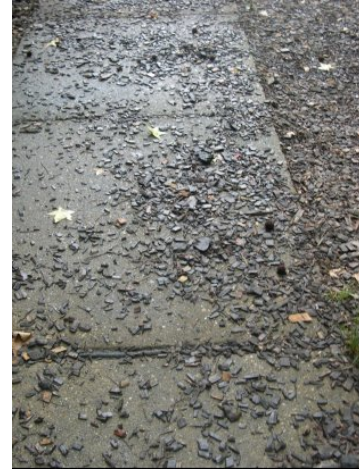

Recommendation: Reconfigure door pair so that primary door to open is on right side (from exterior). Replace automatic door closer with one that can assure a maximum of 5 pounds push pressure. Replace the threshold with a wider, beveled, low profile, threshold.



Gray Smith's Office

Architecture & Community Development
Expert Analysis & Testimony

DELAWARE COMMISSIONER OF ELECTIONS POLLING PLACE ACCESSIBILITY RECOMMENDATIONS	
Name of Polling Place: Aldersgate United Methodist Church (front)	County: New Castle
Address: 2313 Concord Pike, Wilmington	
Contact Person(s) Assisting Survey: Cara Hartsky	
Voting Area: Church: Meeting Room: Front Entrance	

FINDINGS AND RECOMMENDATIONS BASED ON ON-SITE SURVEY AND ADA REQUIREMENTS	
Survey Performed by: Gray Smith AIA AICP Survey Date: June 28, 2005	
<p>Note: This facility contains 2 polling places. The following discussion concerns the polling place entered from the front entrance.</p> <ol style="list-style-type: none">1. Entrance Walkway: The concrete entrance walkway has one displacement at a joint with a raised edge higher than ½ inch. Recommendation: Cut out joint and bevel with epoxy cement patch.2. Entrance doors: The entrance doors (a pair) each require 20 pounds of push pressure to open. Recommendation: Adjust or replace automatic door closers to assure a maximum 5 pounds push pressure.	 

Gray Smith's Office

Architecture & Community Development
Expert Analysis & Testimony

DELAWARE COMMISSIONER OF ELECTIONS POLLING PLACE ACCESSIBILITY RECOMMENDATIONS	
Name of Polling Place: Aldersgate United Methodist Church (rear)	County: New Castle
Address: 2313 Concord Pike	
Contact Person(s) Assisting Survey: Cara Hartsky	
Voting Area: Church: Meeting Room: Rear Entrance	

FINDINGS AND RECOMMENDATIONS BASED ON ON-SITE SURVEY AND ADA REQUIREMENTS

Survey Performed by: Gray Smith AIA AICP
Survey Date: June 28, 2005

(Note: This facility contains 2 polling places. The following discussion concerns the polling place entered from the **rear entrance**.)

- 1. Parking:** Parking in the rear lot does not include accessible parking spaces.

Recommendation: Reconfigure and paint parking spaces adjacent to entrance ramp, with side access aisles, and one van-accessible space, as indicated in the drawing below. Add upright or wall-mounted signs at 5 feet high including "van-accessible" sign.

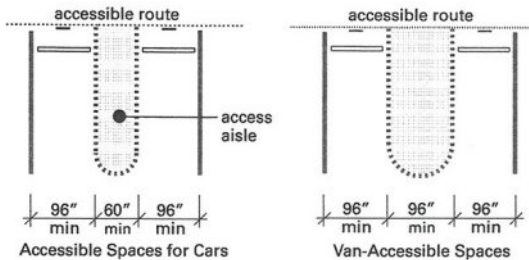

Gray Smith's Office

Architecture & Community Development
Expert Analysis & Testimony

Name of Polling Place: Aldersgate Methodist Church #2 **County:** New Castle
FINDINGS AND RECOMMENDATIONS BASED ON ON-SITE SURVEY AND ADA REQUIREMENTS
Survey Performed by: Gray Smith AIA AICP
Survey Date: June 28, 2005

- 2. Entrance ramp:** The entrance ramp has a handrail on only one side, and which does not extend beyond the top or bottom ends of the ramp. The transition at the concrete ramp surface and wood landing at the bottom has a raised edge greater than 1/2 inch high.

Recommendation: Install handrail on other side of ramp that also extends 12 inches beyond the top and bottom of the ramp. Add extensions to the top and bottom of the ramp. See drawing below. Raise wood landing with shims to level with ramp end.

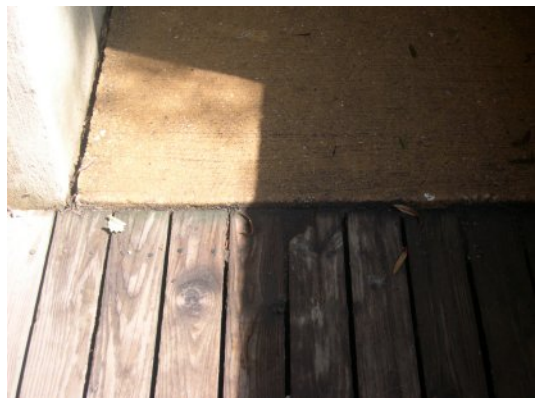
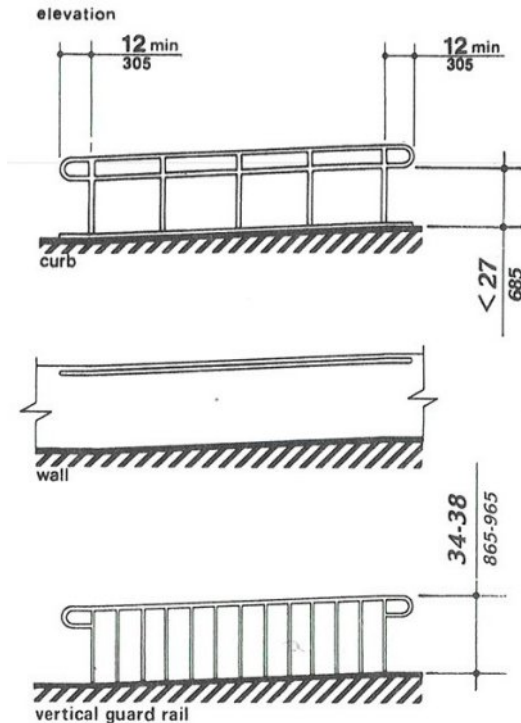

Gray Smith's Office

Architecture & Community Development
Expert Analysis & Testimony

Name of Polling Place: Aldersgate Methodist Church #2 **County:** New Castle

FINDINGS AND RECOMMENDATIONS BASED ON ON-SITE SURVEY AND ADA REQUIREMENTS

Survey Performed by: Gray Smith AIA AICP

Survey Date: June 28, 2005

- 3. Entrance door:** The entrance door requires a push pressure of 20 pounds to open.

Recommendation: Adjust or replace automatic door closer to assure a maximum of 5 pounds push pressure.

- 4. Doors to polling place:** The 2 doors have doorknobs.

Recommendation: Replace doorknobs with lever handles.

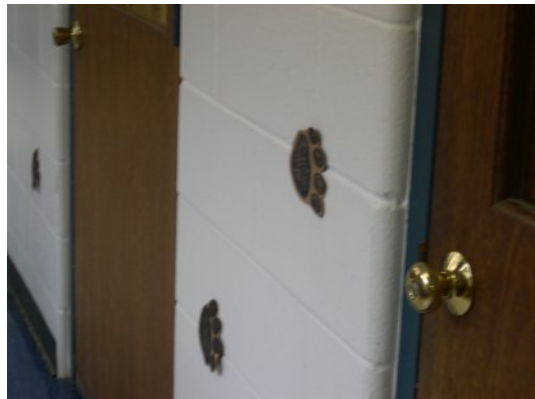

Gray Smith's Office

Architecture & Community Development
Expert Analysis & Testimony

DELAWARE COMMISSIONER OF ELECTIONS POLLING PLACE ACCESSIBILITY RECOMMENDATIONS	
Name of Polling Place: Latin-American Community Center	County: New Castle
Address: 403 N. Van Buren Street, Wilmington	
Contact Person(s) Assisting Survey: Cara Hartsky	
Voting Area: Community Center: Community Room	

FINDINGS AND RECOMMENDATIONS BASED ON ON-SITE SURVEY AND ADA REQUIREMENTS

Survey Performed by: Gray Smith AIA AICP

Survey Date: June 28, 2005

- 1. Parking:** Parking for the polling place is temporary on election day – on the street at the rear of the facility (there is no on-site parking.) There is a continuous raised curb.

Recommendation: Coordinate with the local Department of Streets to designate 2 permanent, accessible, on-street parking spaces with signs. Install 2 intermediate curb ramps as indicated in the following drawing.

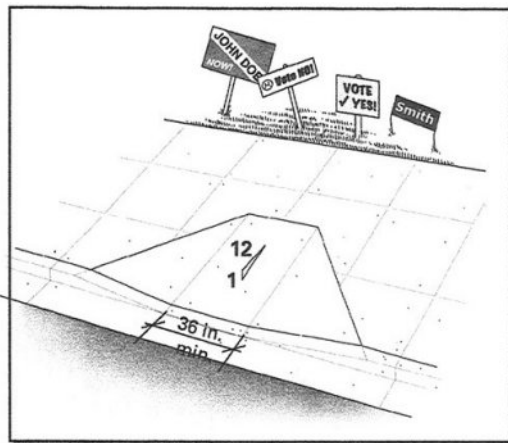

Curb ramp showing minimum 36 inch width for ramp section and 1:12 slope on ramp section.

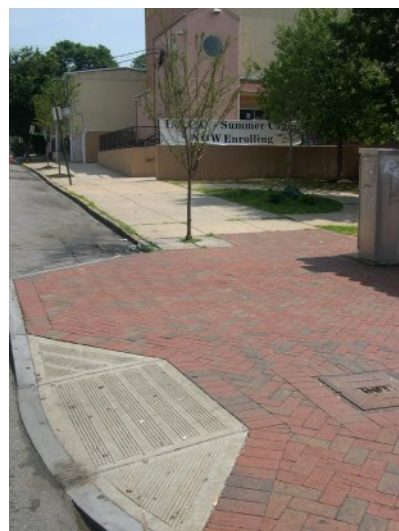

Gray Smith's Office

Architecture & Community Development
Expert Analysis & Testimony

Name of Polling Place: Latin-American Community Center **County:** New Castle
FINDINGS AND RECOMMENDATIONS BASED ON ON-SITE SURVEY AND ADA REQUIREMENTS
Survey Performed by: Gray Smith AIA AICP
Survey Date: June 28, 2005

- 2. Entrance and interior doors:** The exterior and interior doors to the polling place require 12 to 17 pounds push pressure to open.

Recommendation: Adjust or replace automatic door closers to assure a maximum 5 pounds push pressure. In the alternative, prop open the interior doors continuously on election day.



- 3. Signage:** On election day, provide prominent signage at the main front entrance directing voters to the rear entrance to the polling place.



Gray Smith's Office

Architecture & Community Development
Expert Analysis & Testimony

DELAWARE COMMISSIONER OF ELECTIONS POLLING PLACE ACCESSIBILITY RECOMMENDATIONS	
Name of Polling Place: St. Hedwig's Catholic Church	County: New Castle
Address: 408 S. Harrison Street, Wilmington	
Contact Person(s) Assisting Survey: Cara Hartsky	
Voting Area: Church: Monsignor Gulcz Hall (Basement)	

FINDINGS AND RECOMMENDATIONS BASED ON ON-SITE SURVEY AND ADA REQUIREMENTS

Survey Performed by: Gray Smith AIA AICP

Survey Date: June 28, 2005

- 1. Parking:** On-street parking for disabled is marked by signage along the raised curb adjacent to the church; however, access requires travel in the street to a rear driveway curb cut.

Recommendation: Coordinate with local Department of Streets to better designate accessible spaces with painting. Alter the public sidewalk to for an intermediate curb ramps as indicated in the following drawing.

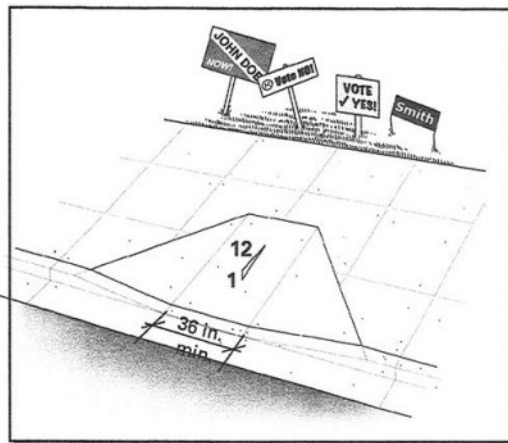

Curb ramp showing minimum 36 inch width for ramp section and 1:12 slope on ramp section.



Gray Smith's Office

Architecture & Community Development
Expert Analysis & Testimony

Name of Polling Place: St. Hedwig's Catholic Church **County:** New Castle

FINDINGS AND RECOMMENDATIONS BASED ON ON-SITE SURVEY AND ADA REQUIREMENTS

Survey Performed by: Gray Smith AIA AICP

Survey Date: June 28, 2005

- 2. Alternative Entrance:** The main entrance to the polling place is by steps. The alternate entrance for disabled is through a rear yard, a heavy door, an unsightly, rear, service entrance, an overly steep ramp with no landing, and a Kitchen.

Recommendation: Consider relocation of the polling place to the main entry Vestibule (Narthex) of the church. Entry would be by way of the existing entrance ramp on the side of the Sanctuary and through the Sanctuary to the Vestibule. In the alternative, modification of the current entrance to the Basement would require sidewalk excavation and construction of a long turn – back ramp, with landings, to replace the steps. The current alternative entrance through the Kitchen is unsuitable even if improved.



Gray Smith's Office

Architecture & Community Development
Expert Analysis & Testimony

Name of Polling Place: St. Hedwig's Catholic Church **County:** New Castle
FINDINGS AND RECOMMENDATIONS BASED ON ON-SITE SURVEY AND ADA REQUIREMENTS
Survey Performed by: Gray Smith AIA AICP
Survey Date: June 28, 2005



Gray Smith's Office

Architecture & Community Development
Expert Analysis & Testimony

DELAWARE COMMISSIONER OF ELECTIONS POLLING PLACE ACCESSIBILITY RECOMMENDATIONS	
Name of Polling Place: Girls, Inc. – Dennison Branch	County: New Castle
Address: 1019 Brown Street, Wilmington	
Contact Person(s) Assisting Survey: Cara Hartsky	
Voting Area: Community Youth Center: Multi-purpose Room	

FINDINGS AND RECOMMENDATIONS BASED ON ON-SITE SURVEY AND ADA REQUIREMENTS

Survey Performed by: Gray Smith AIA AICP

Survey Date: June 28, 2005

Note: During the visit, engineers were on-site with drawing of proposed improvement work, including some accessibility work. They indicated that the work was expected to occur soon.

- 1. Parking:** There was no accessible parking on-site.

Recommendation: Designate 2 accessible parking spaces adjacent to entrance with one as van-accessible. Install wall-mounted signs at 5 feet high, with “van-accessible” sign. See drawing below.

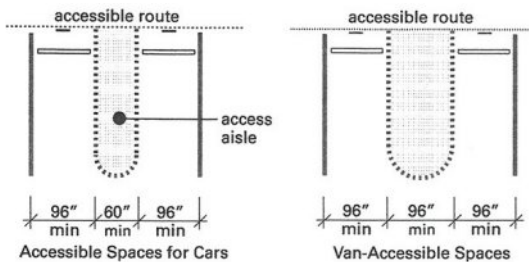

Gray Smith's Office

Architecture & Community Development
Expert Analysis & Testimony

Name of Polling Place: Girls, Inc. – Dennison Branch **County:** New Castle
FINDINGS AND RECOMMENDATIONS BASED ON ON-SITE SURVEY AND ADA REQUIREMENTS
Survey Performed by: Gray Smith AIA AICP
Survey Date: June 28, 2005

- 2. Route to entrance:** One vertical edge within the walkway was over ½ inch high.

Recommendation: Cut down and bevel edge for even transition.

- 3. Entry steps:** Adjacent to the entry ramp, there were 2 steps without handrails.

Recommendation: Install handrails on both sides of steps with extension at the top and bottom as indicated in the following drawing.

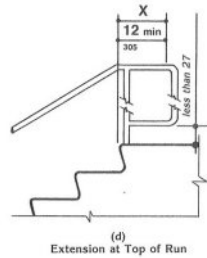
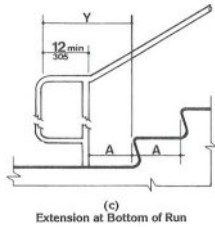

- 4. Entrance door:** The entrance door required a 16 pounds push pressure to open.

Recommendation: Adjust or replace automatic door closer to assure a maximum 5 pounds push pressure.

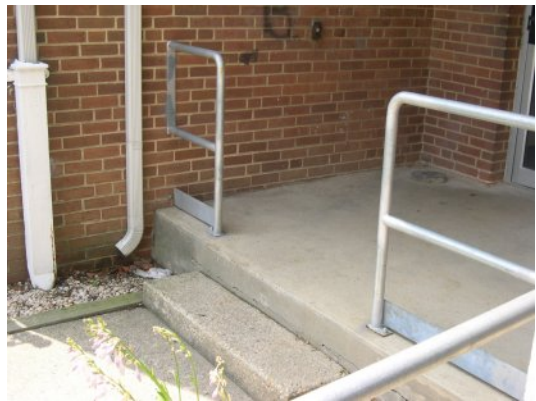

Gray Smith's Office

Architecture & Community Development
Expert Analysis & Testimony

DELAWARE COMMISSIONER OF ELECTIONS POLLING PLACE ACCESSIBILITY RECOMMENDATIONS	
Name of Polling Place: West End Neighborhood House	County: New Castle
Address: 710 N. Lincoln Street, Wilmington	
Contact Person(s) Assisting Survey: Cara Hartsky	
Voting Area: Community Center: Multi-purpose Room	

FINDINGS AND RECOMMENDATIONS BASED ON ON-SITE SURVEY AND ADA REQUIREMENTS

Survey Performed by: Gray Smith AIA AICP

Survey Date: June 28, 2005

- Parking:** Two accessible parking spaces were provided; however, there was no van-accessible space, no upright signs and the surface paint had worn away.

Recommendation: Near to the entrance, reconfigure and repaint at least 2 accessible parking spaces and side access aisles, one to be van-accessible as indicated in the drawing below. Add upright signs at 5 feet high, with "van-accessible" sign.

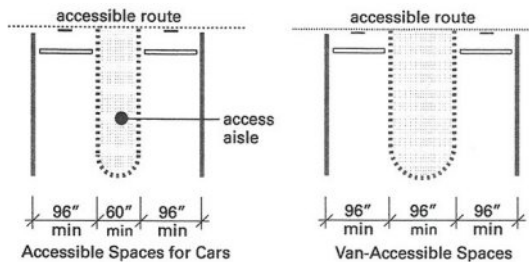

Gray Smith's Office

Architecture & Community Development
Expert Analysis & Testimony

Name of Polling Place: West End Neighborhood House **County:** New Castle

FINDINGS AND RECOMMENDATIONS BASED ON ON-SITE SURVEY AND ADA REQUIREMENTS

Survey Performed by: Gray Smith AIA AICP

Survey Date: June 28, 2005

- 2. Route from public sidewalk:** Persons arriving by foot or wheelchair from the public sidewalk must pass over a continuous storm water drain at the edge of the parking lot driveway. The metal drain inlets and the surrounding concrete are warped, cracked and hazardous.

Recommendation: Repair and stabilize entire storm water inlet for level passage.



- 3. Entrance doors:** The entrance doors require a 20 pound push pressure to open. The threshold has a raised concrete edge greater than ½ inch.

Recommendation: Adjust or replace automatic door closers to assure a maximum of 5 pounds push pressure. Repair concrete by cutting out and refilling with beveled epoxy cement.



Gray Smith's Office

Architecture & Community Development
Expert Analysis & Testimony

DELAWARE COMMISSIONER OF ELECTIONS POLLING PLACE ACCESSIBILITY RECOMMENDATIONS	
Name of Polling Place: Zion Lutheran Church	County: New Castle
Address: 2101 Lancaster Avenue, Wilmington	
Contact Person(s) Assisting Survey: Cara Hartsky	
Voting Area: Church	

FINDINGS AND RECOMMENDATIONS BASED ON ON-SITE SURVEY AND ADA REQUIREMENTS

Survey Performed by: Gray Smith AIA AICP

Survey Date: June 28, 2005

Note: The interior of this facility was not available for entry at the time of the visit.

- 1. Parking:** Two accessible parking spaces were located near the main entrance; however, they did not have upright signs or side access aisles.

Recommendation: Repaint the accessible spaces to expand and allow for a 36 inches side parallel aisle on the building side. Install upright signs at 5 feet high, including one "van-accessible" sign.



- 2. Entrance doors:** Each of the doors in the pair, when open, would allow only 30 inches clear.

Recommendation: On election day, have personnel available to open both doors for wheelchairs.



Gray Smith's Office

Architecture & Community Development
Expert Analysis & Testimony

DELAWARE COMMISSIONER OF ELECTIONS POLLING PLACE ACCESSIBILITY RECOMMENDATIONS	
Name of Polling Place: Elsmere Fire Company #1	County: New Castle
Address: 1107 New Road, Wilmington	
Contact Person(s) Assisting Survey: Cara Hartsky	
Voting Area: Volunteer Fire Hall: Banquet Hall	

FINDINGS AND RECOMMENDATIONS BASED ON ON-SITE SURVEY AND ADA REQUIREMENTS

Survey Performed by: Gray Smith AIA AICP

Survey Date: June 28, 2005

Note: The interior of this facility was not available during the visit.

- 1. Parking:** Accessible parking spaces were provided; however, there was no "van-accessible" sign at the van-accessible space.

Recommendation: Provide a "van-accessible" sign.

- 2. Signage:** "Handicapped" was painted on entrance canopy.

Recommendation: It is suggested that the canopy language be covered and that a simple universal accessibility symbol sign be placed by the door. Also place a sign at the main entrance directing to the accessible entrance.



Gray Smith's Office

Architecture & Community Development
Expert Analysis & Testimony



DELAWARE COMMISSIONER OF ELECTIONS POLLING PLACE ACCESSIBILITY RECOMMENDATIONS	
Name of Polling Place: Elsmere Public Library & Elsmere Town Hall	County: New Castle
Address: 30 Spruce Avenue, Wilmington	
Contact Person(s) Assisting Survey: Cara Hartsky	
Voting Area: Library: 2 voting areas: Community Rooms	

FINDINGS AND RECOMMENDATIONS BASED ON ON-SITE SURVEY AND ADA REQUIREMENTS	
Survey Performed by: Gray Smith AIA AICP Survey Date: June 28, 2005	
It is noted that this facility was completely barrier-free and in compliance with the ADA.	

Gray Smith's Office

Architecture & Community Development
Expert Analysis & Testimony

DELAWARE COMMISSIONER OF ELECTIONS POLLING PLACE ACCESSIBILITY RECOMMENDATIONS	
Name of Polling Place: Five Points Fire Hall	County: New Castle
Address: 209 S. Maryland Avenue	
Contact Person(s) Assisting Survey: Cara Hartsky	
Voting Area: Volunteer Fire Hall: Banquet Room	

FINDINGS AND RECOMMENDATIONS BASED ON ON-SITE SURVEY AND ADA REQUIREMENTS	
<p>Survey Performed by: Gray Smith AIA AICP Survey Date: June 28, 2005</p>	
<p>Note: The interior of this facility was not available during the visit.</p> <p>Parking: The parking lot had just recently been recoated and no surface striping was applied.</p> <p>Recommendation: Assure the surface painting includes at least 2 accessible parking spaces with side access aisles and one van-accessible space. Include upright or wall-mounted signs at 5 feet high, and one "van-accessible" sign.</p> <div style="text-align: center;">  </div>	

Gray Smith's Office

Architecture & Community Development
Expert Analysis & Testimony

DELAWARE COMMISSIONER OF ELECTIONS POLLING PLACE ACCESSIBILITY RECOMMENDATIONS	
Name of Polling Place: Peniel United Methodist Church	County: New Castle
Address: 115 E. Market Street, Newport	
Contact Person(s) Assisting Survey: Cara Hartsky	
Voting Area: Church: Social Hall	

FINDINGS AND RECOMMENDATIONS BASED ON ON-SITE SURVEY AND ADA REQUIREMENTS

Survey Performed by: Gray Smith AIA AICP
Survey Date: June 28, 2005

- 1. Parking:** Accessible parking is provided; however, each space does not have an upright sign.

Recommendation: Install upright signs at 5 feet high at each accessible parking space with "van-accessible" signs at van-accessible spaces. Install wheelstops in each space to prevent vehicle contact with signs.

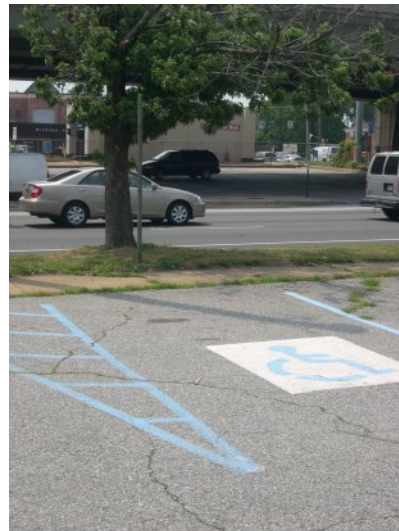

Gray Smith's Office

Architecture & Community Development
Expert Analysis & Testimony

Name of Polling Place: Peniel United Methodist Church **County:** New Castle
FINDINGS AND RECOMMENDATIONS BASED ON ON-SITE SURVEY AND ADA REQUIREMENTS
Survey Performed by: Gray Smith AIA AICP
Survey Date: June 28, 2005

- 2. Route to entrance:** A raised concrete edge in the walkway is higher than ½ inch.

Recommendation: Cut out and patch area with beveled epoxy cement.

- 3. Entrance door:** The entrance door has several defects:

- when open, the door allows less than 32 inches clear;
- the door swings out on the wrong side and is an obstruction;
- the handle is a doorknob;
- the push pressure is 20 pounds to open.

Recommendation: Remove and replace the door and frame with a wider door and a narrow frame, lever handles and a new automatic door closer with a maximum push pressure of 5 pounds. Swing door towards side wall. Include view panel in door.

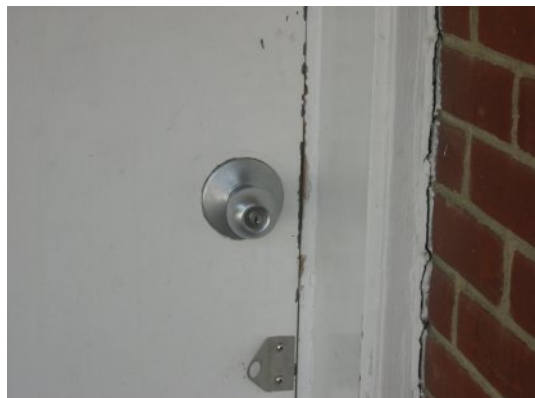

Gray Smith's Office

Architecture & Community Development
Expert Analysis & Testimony

Name of Polling Place: Peniel United Methodist Church **County:** New Castle

FINDINGS AND RECOMMENDATIONS BASED ON ON-SITE SURVEY AND ADA REQUIREMENTS

Survey Performed by: Gray Smith AIA AICP

Survey Date: June 28, 2005

- 4. Interior door:** The interior door to the polling place has only a 29 inches clear area, in lieu of 32 inches.

Recommendation: Widening the door requires removal on one side of the frame and expanding at least 5 inches, removal of a step and the corner of a stage, and relocation of the stage access steps to the other corner of the stage. Replace door with new door if door is necessary.



Gray Smith's Office

Architecture & Community Development
Expert Analysis & Testimony

DELAWARE COMMISSIONER OF ELECTIONS POLLING PLACE ACCESSIBILITY RECOMMENDATIONS	
Name of Polling Place: Nur Shriners (Nur Temple)	County: New Castle
Address: 198 S. Dupont Highway, New Castle	
Contact Person(s) Assisting Survey: Cara Hartsky	
Voting Area: Shriners Temple: Party Room	

FINDINGS AND RECOMMENDATIONS BASED ON ON-SITE SURVEY AND ADA REQUIREMENTS
Survey Performed by: Gray Smith AIA AICP
Survey Date: June 28, 2005

1. Parking: Accessible parking is ample; however, no space is specifically van-accessible. Surface paint is worn away.

Recommendation: Repaint surface striping and include one accessible space with side access aisle as indicated in the drawing below. Include "van-accessible" wall-mounted sign.

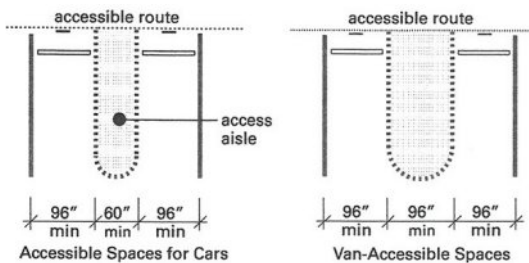

Gray Smith's Office

Architecture & Community Development
Expert Analysis & Testimony

Name of Polling Place: Nur Shriners (Nur Temple) **County:** New Castle

FINDINGS AND RECOMMENDATIONS BASED ON ON-SITE SURVEY AND ADA REQUIREMENTS

Survey Performed by: Gray Smith AIA AICP

Survey Date: June 28, 2005

- 2. Entrance door:** The entrance door requires a push pressure of 17 pounds to open.

Recommendation: Adjust or replace automatic door closer to assure a maximum of 5 pounds push pressure.



Gray Smith's Office

Architecture & Community Development
Expert Analysis & Testimony

DELAWARE COMMISSIONER OF ELECTIONS POLLING PLACE ACCESSIBILITY RECOMMENDATIONS	
Name of Polling Place: B'Nai B'Rith House	County: New Castle
Address: 8000 Society Drive, Claymont	
Contact Person(s) Assisting Survey: Cara Hartsky	
Voting Area: Senior Apartment Building: Multi-Purpose Room	

FINDINGS AND RECOMMENDATIONS BASED ON ON-SITE SURVEY AND ADA REQUIREMENTS

Survey Performed by: Gray Smith AIA AICP

Survey Date: June 17, 2005

- 1. Parking:** Two accessible parking spaces are reserved on election day for disabled; however, there is no van-accessible space and no upright signs. In addition, the curb ramp to the walkway at the accessible parking spaces is a built-up ramp within the side access aisle.

Recommendation: Reconfigure the 2 parking spaces, side access aisle and remove the built-up curb ramp. Expand parking spaces with wider side access aisle for van-accessible space, as indicated in the drawing below. Widen and modify the concrete walkway to accommodate a new concrete curb ramp within the walkway (not in the access aisle) as in the second drawing below. Install upright signs at 5 feet high, including "van-accessible" signs.



Gray Smith's Office

Architecture & Community Development
Expert Analysis & Testimony

Name of Polling Place: B'Nai B'Rith House **County:** New Castle
FINDINGS AND RECOMMENDATIONS BASED ON ON-SITE SURVEY AND ADA REQUIREMENTS
Survey Performed by: Gray Smith AIA AICP
Survey Date: June 17, 2005

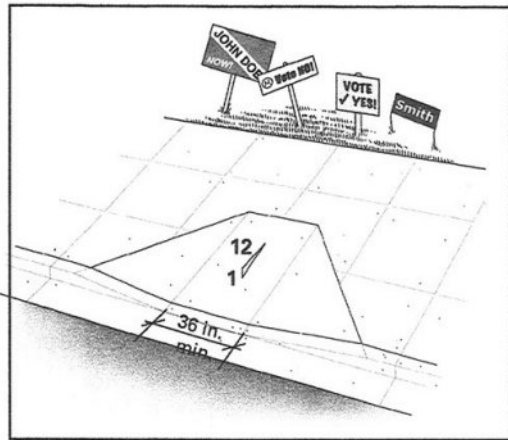
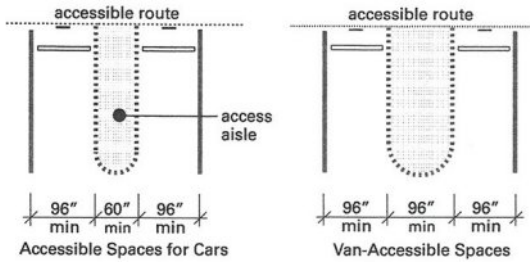

Curb ramp showing minimum 36 inch width for ramp section and 1:12 slope on ramp section.

Gray Smith's Office

Architecture & Community Development
Expert Analysis & Testimony

DELAWARE COMMISSIONER OF ELECTIONS POLLING PLACE ACCESSIBILITY RECOMMENDATIONS	
Name of Polling Place: Captain's Deck	County: New Castle
Address: 7807 Governor Printz Boulevard, Claymont	
Contact Person(s) Assisting Survey: Cara Hartsky	
Voting Area: Senior Apartment Building: Side Dining Room	

FINDINGS AND RECOMMENDATIONS BASED ON ON-SITE SURVEY AND ADA REQUIREMENTS
Survey Performed by: Gray Smith AIA AICP
Survey Date: June 17, 2005

1. Parking: There are numerous parking spaces designated on the surface and by upright signs as accessible; however, there are no side access aisles and no van-accessible spaces.

Recommendation: Reconfigure and repaint the accessible parking spaces to include intermediate side aisles and at least one van-accessible space, in accordance with the drawing below. Move the upright signs to correspond to the spacing and add a "van-accessible" sign.

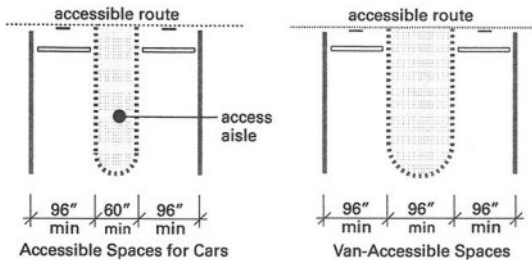

Gray Smith's Office

Architecture & Community Development
Expert Analysis & Testimony

DELAWARE COMMISSIONER OF ELECTIONS POLLING PLACE ACCESSIBILITY RECOMMENDATIONS	
Name of Polling Place: Rosehill Community Center	County: New Castle
Address: 19 Lambsons Lane, New Castle	
Contact Person(s) Assisting Survey: Cara Hartsky	
Voting Area: Community Center (previously a school)	

FINDINGS AND RECOMMENDATIONS BASED ON ON-SITE SURVEY AND ADA REQUIREMENTS

Survey Performed by: Gray Smith AIA AICP
Survey Date: June 17, 2005

- Parking:** There are designated accessible parking spaces; however, there is no van accessible space, no side access aisles, no upright signs, and the paint has worn away.

Recommendation: Reconfigure and repaint accessible parking area to include side access aisles and one van-accessible space, upright signs (or wall-mounted) at 5 feet high with a "van-accessible" sign, in accordance with the following drawing.

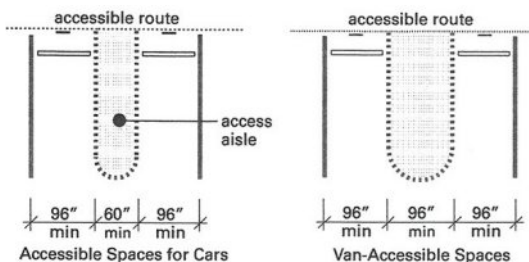

Gray Smith's Office

Architecture & Community Development
Expert Analysis & Testimony

Name of Polling Place: Rosehill Community Center **County:** New Castle

FINDINGS AND RECOMMENDATIONS BASED ON ON-SITE SURVEY AND ADA REQUIREMENTS

Survey Performed by: Gray Smith AIA AICP

Survey Date: June 17, 2005

- 2. Entrance ramp:** A compliant ramp is provided; however, a gap is located at the top end of the ramp.

Recommendation: Repair gap with epoxy cement to level surface.

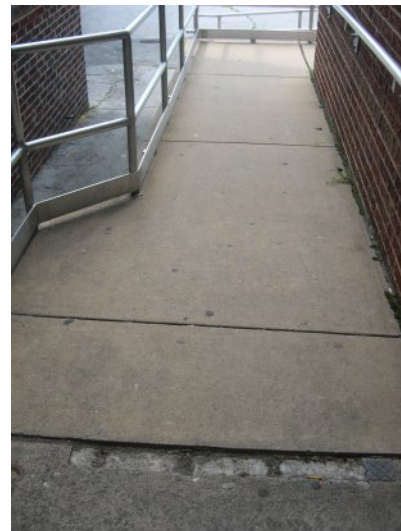

- 3. Entrance door:** The entrance door requires a push pressure of 15 pounds.

Recommendation: Adjust or replace automatic door closer to assure a maximum push pressure of 5 pounds.

Gray Smith's Office

Architecture & Community Development
Expert Analysis & Testimony

DELAWARE COMMISSIONER OF ELECTIONS POLLING PLACE ACCESSIBILITY RECOMMENDATIONS	
Name of Polling Place: Minquadale Fire Company	County: New Castle
Address: 129 E. Hazeldell Avenue, New Castle	
Contact Person(s) Assisting Survey: Cara Hartsky	
Voting Area: Volunteer Fire Company: "Wedding Hall"	

FINDINGS AND RECOMMENDATIONS BASED ON ON-SITE SURVEY AND ADA REQUIREMENTS
Survey Performed by: Gray Smith AIA AICP
Survey Date: June 17, 2005

1. Parking: Accessible parking spaces are provided, but the paint has worn away, and there is no van-accessible space. There are no upright signs.

Recommendation: Reconfigure and repaint accessible parking spaces in accordance with the drawing below. Include one van-accessible space and upright (or wall-mounted) signs at 5 feet high, including a "van-accessible" sign.

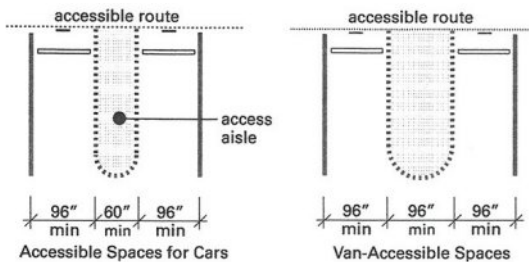

Gray Smith's Office

Architecture & Community Development
Expert Analysis & Testimony

Name of Polling Place: Minquadale Fire Company **County:** New Castle

FINDINGS AND RECOMMENDATIONS BASED ON ON-SITE SURVEY AND ADA REQUIREMENTS

Survey Performed by: Gray Smith AIA AICP

Survey Date: June 17, 2005

- 2. Entrance door:** The entrance door requires a 17-pound push pressure to open.

Recommendation: Adjust or replace automatic door closer to assure a maximum push pressure of 5 pounds.



Gray Smith's Office

Architecture & Community Development
Expert Analysis & Testimony

DELAWARE COMMISSIONER OF ELECTIONS POLLING PLACE ACCESSIBILITY RECOMMENDATIONS	
Name of Polling Place: Howard Weston Senior Center	County: New Castle
Address: 1 Bassett Avenue, New Castle	
Contact Person(s) Assisting Survey: Cara Hartsky	
Voting Area: Senior Citizen Center: Multi-Purpose Room	

FINDINGS AND RECOMMENDATIONS BASED ON ON-SITE SURVEY AND ADA REQUIREMENTS

Survey Performed by: Gray Smith AIA AICP

Survey Date: June 17, 2005

- 1. Parking:** Accessible parking spaces are provided; however, there are no upright signs and the surface paint is worn.

Recommendation: Repaint surface; provide upright signs at 5 feet high, including "van-accessible" signs for all van-accessible spaces. Put wheelstops in all parking spaces and adjacent to signs to protect from vehicle contact.

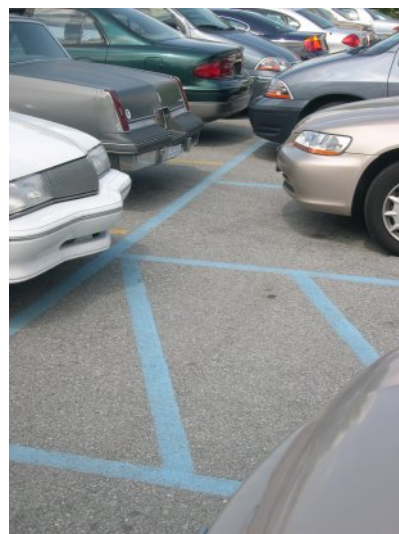

Gray Smith's Office

Architecture & Community Development
Expert Analysis & Testimony

Name of Polling Place: Howard Weston Senior Center **County:** New Castle

FINDINGS AND RECOMMENDATIONS BASED ON ON-SITE SURVEY AND ADA REQUIREMENTS

Survey Performed by: Gray Smith AIA AICP

Survey Date: June 17, 2005

- 2. Entrance door:** The entrance door requires a push pressure of 17-pounds to open.

Recommendation: Adjust or replace automatic door closer to assure a maximum of 5 pounds push pressure.



- 3. Interior doors:** The interior Vestibule door requires a push pressure of 10 pounds to open.

Recommendation: Adjust or replace automatic door closer to assure a maximum of 5 pounds push pressure.

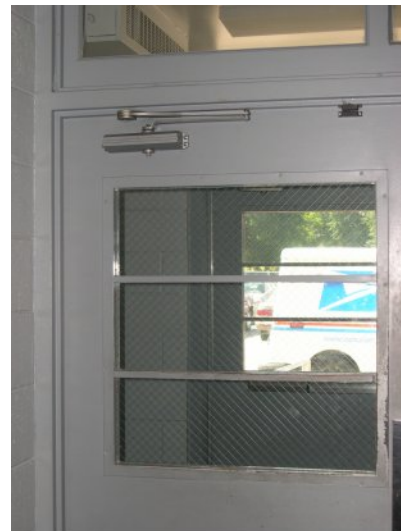

- 4. Exterior lighting:** One of the lights at the entrance was missing a bulb and globe.

Recommendation: Replace bulb and globe to assure adequate illumination on election day (night).



Gray Smith's Office

Architecture & Community Development
Expert Analysis & Testimony

DELAWARE COMMISSIONER OF ELECTIONS POLLING PLACE ACCESSIBILITY RECOMMENDATIONS	
Name of Polling Place: New Castle United Methodist Church	County: New Castle
Address: 510 Delaware Street, New Castle	
Contact Person(s) Assisting Survey: Cara Hartsky	
Voting Area: Church: Fellowship Hall	

FINDINGS AND RECOMMENDATIONS BASED ON ON-SITE SURVEY AND ADA REQUIREMENTS

Survey Performed by: Gray Smith AIA AICP
Survey Date: June 17, 2005

- 1. Parking:** Accessible parking spaces were provided; however: there were no intermediate side access aisles; the surface paint was worn away; only 2 (of 4) had wall-mounted signs that were mounted too low; and there was no van-accessible space. Several downspouts spill onto the parking surface for a potential for ice accumulation.

Recommendation: Reconfigure and repaint accessible parking spaces in accordance with drawing below. Include van-accessible space, and wall-mounted signs up 5 feet with one "van-accessible" sign. Assure ice-melt chemicals are available on election day.

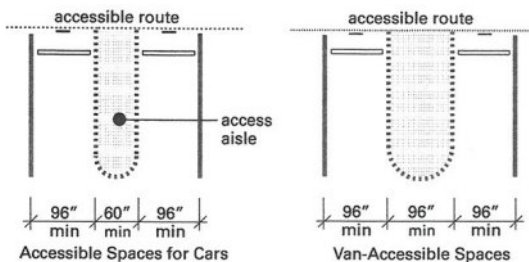

Gray Smith's Office

Architecture & Community Development
Expert Analysis & Testimony

Name of Polling Place: New Castle United Methodist **County:** New Castle

FINDINGS AND RECOMMENDATIONS BASED ON ON-SITE SURVEY AND ADA REQUIREMENTS

Survey Performed by: Gray Smith AIA AICP

Survey Date: June 17, 2005

- 2. Entrance ramp and landing:** A small ramp and landing at the entrance did not have a guard rail at the 4 ½ inches high landing edge, a slip-off hazard. Also, there was no handrail on one side.

Recommendation: Install a wall-mounted handrail on one side with a 12 inches extension at the bottom. Add guardrails on the 2 open sides of the landing (match existing handrail) to prevent accidental slipping off the edge by a wheelchair.

- 3. Entrance door:** The entrance door requires a 10 pound push pressure to open. The threshold has a vertical edge greater than ½ inch.

Recommendation: Adjust or replace the automatic door closer to assure a maximum 5 pounds push pressure. Replace the threshold with a wider, beveled, low-profile, aluminum threshold.

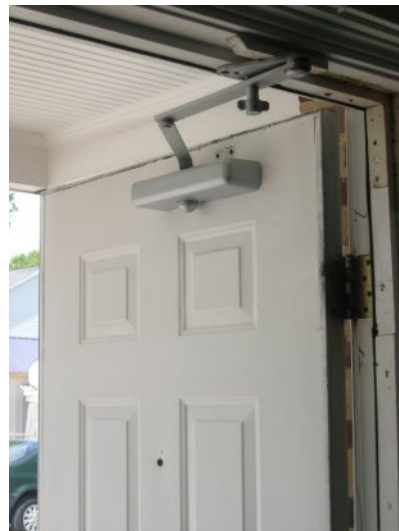

Gray Smith's Office

Architecture & Community Development
Expert Analysis & Testimony

DELAWARE COMMISSIONER OF ELECTIONS POLLING PLACE ACCESSIBILITY RECOMMENDATIONS	
Name of Polling Place: Goodwill Fire Company	County: New Castle
Address: 401 South Street, New Castle	
Contact Person(s) Assisting Survey: Cara Hartsky	
Voting Area: Volunteer Fire Hall: Engine Room	

FINDINGS AND RECOMMENDATIONS BASED ON ON-SITE SURVEY AND ADA REQUIREMENTS

Survey Performed by: Gray Smith AIA AICP
Survey Date: June 17, 2005

- Parking:** Two accessible parking spaces are provided; however, they do not have side access aisles, and only one upright sign is provided, improperly worded. Neither space is van-accessible.

Recommendation: Reconfigure and repaint the 2 spaces as in the drawing below, to include side access aisles on the curbside (relocate curb if necessary). Add one "van-accessible" sign, and 2 upright signs.

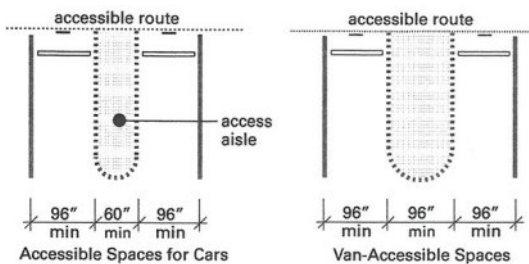

Gray Smith's Office

Architecture & Community Development
Expert Analysis & Testimony

Name of Polling Place: Goodwill Fire Company **County:** New Castle
FINDINGS AND RECOMMENDATIONS BASED ON ON-SITE SURVEY AND ADA REQUIREMENTS
Survey Performed by: Gray Smith AIA AICP
Survey Date: June 17, 2005

2. Alternate entrance route: Disabled persons must use an alternative route to the polling place by the opening of the large Engine Room overhead door (even on cold days). Curbs and steps at the main entrance are barriers.

Recommendation: Upgrade the main entrance for use by disabled persons, as follows: construct a curb ramp (see drawing below) within the curb near the entrance, or as an extension of the side access aisles of the parking spaces. Construct a concrete ramp and 5 feet x 5 feet landing to reach the main entrance (see drawing below). Include handrails on ramp and guardrails on landing.

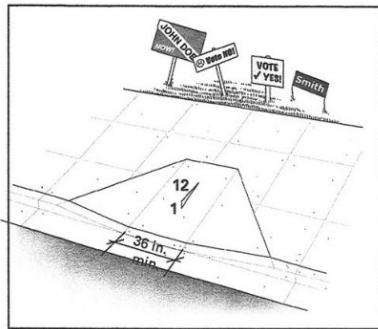

Curb ramp showing minimum 36 inch width for ramp section and 1:12 slope on ramp section.

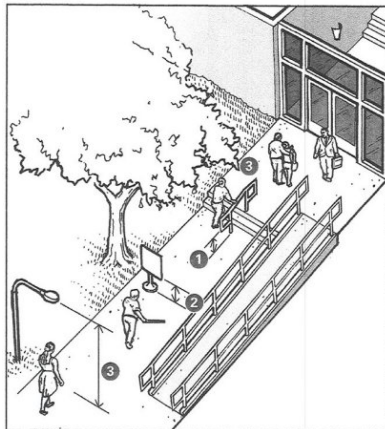

Gray Smith's Office

Architecture & Community Development
Expert Analysis & Testimony

Name of Polling Place: Goodwill Fire Company **County:** New Castle

FINDINGS AND RECOMMENDATIONS BASED ON ON-SITE SURVEY AND ADA REQUIREMENTS

Survey Performed by: Gray Smith AIA AICP

Survey Date: June 17, 2005

- 3. Interior doors:** Interior doors have doorknobs.

Recommendation: Replace all interior doorknobs with lever handles on all doors that voters will use.



- 4. Curbs at driveway:** Disabled voters not arriving by vehicle might encounter the curbs at the driveway and the public sidewalk.

Recommendation: Construct simple curb ramps at driveway/sidewalk transitions, to eliminate level change.



Gray Smith's Office

Architecture & Community Development
Expert Analysis & Testimony

DELAWARE COMMISSIONER OF ELECTIONS POLLING PLACE ACCESSIBILITY RECOMMENDATIONS	
Name of Polling Place: Victory Christian Fellowship	County: New Castle
Address: 100 Wilton Boulevard, New Castle	
Contact Person(s) Assisting Survey: Cara Hartsky	
Voting Area: Church: Community Room	

FINDINGS AND RECOMMENDATIONS BASED ON ON-SITE SURVEY AND ADA REQUIREMENTS
Survey Performed by: Gray Smith AIA AICP
Survey Date: June 17, 2005

1. Parking: There are many accessible parking spaces provided; however, some do not have side access aisles (some do). There are upright signs; however, most are too low, and some are missing.

Recommendation: Reconfigure and repaint accessible spaces to provide side access aisles, including those for van-accessible space(s) in accordance with the drawing below. Raise all upright signs to 5 feet high.

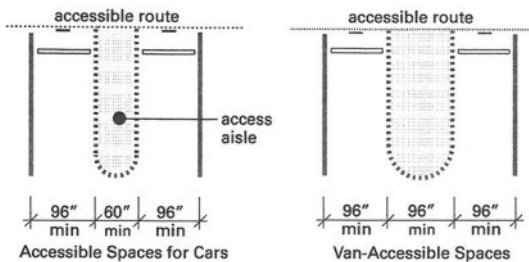

Gray Smith's Office

Architecture & Community Development
Expert Analysis & Testimony

Name of Polling Place: Victory Christian Fellowship **County:** New Castle
FINDINGS AND RECOMMENDATIONS BASED ON ON-SITE SURVEY AND ADA REQUIREMENTS
Survey Performed by: Gray Smith AIA AICP
Survey Date: June 17, 2005

2. Route to entrance: Disabled person parking in the designated spaces must access the entrance by traveling in a busy driveway behind parked vehicles to a central curb ramp, rather than by using side access aisles to the concrete walkway.

Recommendation: After reconfiguration of the parking area, rework the concrete walkway to provide curb ramps at the ends of each side access aisle.



Gray Smith's Office

Architecture & Community Development
Expert Analysis & Testimony

Name of Polling Place: Victory Christian Fellowship **County:** New Castle

FINDINGS AND RECOMMENDATIONS BASED ON ON-SITE SURVEY AND ADA REQUIREMENTS

Survey Performed by: Gray Smith AIA AICP

Survey Date: June 17, 2005

- 3. Entrance and Vestibule doors:** The entrance and Vestibule doors (4 pairs) required 11 to 20 pounds of push pressure to open.

Recommendation: Adjust or replace the automatic door closers to assure a maximum 5 pounds push pressure.



Gray Smith's Office

Architecture & Community Development
Expert Analysis & Testimony

DELAWARE COMMISSIONER OF ELECTIONS POLLING PLACE ACCESSIBILITY RECOMMENDATIONS	
Name of Polling Place: Cokesbury Village	County: New Castle
Address: 726 Loveville Road, Hockessin	
Contact Person(s) Assisting Survey: Cara Hartsky	
Voting Area: Senior Apartment Building: Multi-purpose Room	

FINDINGS AND RECOMMENDATIONS BASED ON ON-SITE SURVEY AND ADA REQUIREMENTS

Survey Performed by: Gray Smith AIA AICP

Survey Date: June 17, 2005

- 1. Parking:** Accessible parking spaces are provided, however, none have upright signs. On election day, some "15 min. parking" spaces are also used for disabled parkers.

Recommendation: Allow election day use of and provide "van-accessible" upright signs at 5 feet high, at two designated accessible spaces. In the alternative, use 2 of the "15 min. parking" spaces with portable accessibility signs and supervision to assist disabled travel within driveways.



Gray Smith's Office

Architecture & Community Development
Expert Analysis & Testimony

DELAWARE COMMISSIONER OF ELECTIONS POLLING PLACE ACCESSIBILITY RECOMMENDATIONS	
Name of Polling Place: Hockessin Fire Company	County: New Castle
Address: 1225 Old Lancaster Pike, Hockessin	
Contact Person(s) Assisting Survey: Cara Hartsky	
Voting Area: Volunteer Fire Hall: Banquet Room	

FINDINGS AND RECOMMENDATIONS BASED ON ON-SITE SURVEY AND ADA REQUIREMENTS
Survey Performed by: Gray Smith AIA AICP
Survey Date: June 17, 2005

1. Parking: Accessible parking spaces are provided; however, there are no side access aisles, the surface paint is worn away, and there are no upright signs.

Recommendation: Reconfigure and repaint accessible spaces in accordance with the drawing below. Assure one van-accessible space. Add upright signs at 5 feet high, including "van-accessible" sign.

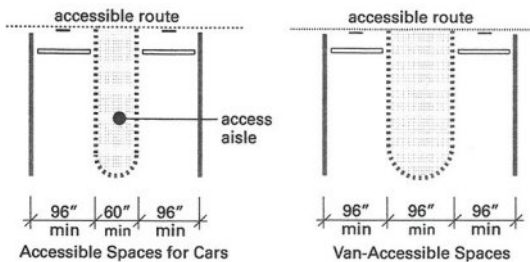

Gray Smith's Office

Architecture & Community Development
Expert Analysis & Testimony

Name of Polling Place: Hockessin Fire Company **County:** New Castle

FINDINGS AND RECOMMENDATIONS BASED ON ON-SITE SURVEY AND ADA REQUIREMENTS

Survey Performed by: Gray Smith AIA AICP

Survey Date: June 17, 2005

- 2. Entrance and interior doors:** The entrance doors require 15 pounds of push pressure to open. The interior Vestibule doors require 10 pounds of push pressure.

Recommendation: Adjust or replace automatic door closers to assure a maximum of 5 pounds push pressure.



Gray Smith's Office

Architecture & Community Development
Expert Analysis & Testimony

DELAWARE COMMISSIONER OF ELECTIONS POLLING PLACE ACCESSIBILITY RECOMMENDATIONS	
Name of Polling Place: Hockessin Police Athletic League	County: New Castle
Address: 7259 Lancaster Pike, Hockessin	
Contact Person(s) Assisting Survey: Cara Hartsky	
Voting Area: Police Athletic League: Multi-purpose Room	

FINDINGS AND RECOMMENDATIONS BASED ON ON-SITE SURVEY AND ADA REQUIREMENTS

Survey Performed by: Gray Smith AIA AICP

Survey Date: June 17, 2005

- 1. Parking:** Designated accessible parking spaces are provided; however, they are located away from the entrance at the bottom of a \pm 70 feet long ramp (with no handrails and no intermediate landings).

Recommendation: Permanently designate and paint the parking spaces just outside the main entrance as accessible. Install upright signs at 5 feet high, and assure one space is van-accessible with "van-accessible" sign. Reserve these spaces on election day.



Gray Smith's Office

Architecture & Community Development
Expert Analysis & Testimony

Name of Polling Place: Hockessin Police Athletic League **County:** New Castle
FINDINGS AND RECOMMENDATIONS BASED ON ON-SITE SURVEY AND ADA REQUIREMENTS
Survey Performed by: Gray Smith AIA AICP
Survey Date: June 17, 2005

- 2. Entrance and Vestibule doors:** On the day of the visit, the automatic opening function of these doors was inoperable. As such, the push pressure to open the doors was from 12 to 16 pounds.

Recommendation: Repair automatic opening function and assure operation on election day.



Gray Smith's Office

Architecture & Community Development
Expert Analysis & Testimony

DELAWARE COMMISSIONER OF ELECTIONS POLLING PLACE ACCESSIBILITY RECOMMENDATIONS	
Name of Polling Place: Hockessin Public Library	County: New Castle
Address: 1023 Valley Road, Hockessin	
Contact Person(s) Assisting Survey: Cara Hartsky	
Voting Area: Library: Community Room	

FINDINGS AND RECOMMENDATIONS BASED ON ON-SITE SURVEY AND ADA REQUIREMENTS	
Survey Performed by: Gray Smith AIA AICP Survey Date: June 17, 2005	
<p>1. Parking: Ample accessible parking spaces were provided, including van-accessible spaces; however, there were no “van-accessible” signs.</p> <p>Recommendation: Install “van-accessible” signs at 2 van-accessible spaces.</p>	 

Gray Smith's Office

Architecture & Community Development
Expert Analysis & Testimony

DELAWARE COMMISSIONER OF ELECTIONS POLLING PLACE ACCESSIBILITY RECOMMENDATIONS	
Name of Polling Place: Delaware City Library & Community Center	County: New Castle
Address: 250 Fifth Street, Delaware City	
Contact Person(s) Assisting Survey: Cara Hartsky	
Voting Area: Library: Meeting Room (formerly a school)	

FINDINGS AND RECOMMENDATIONS BASED ON ON-SITE SURVEY AND ADA REQUIREMENTS
Survey Performed by: Gray Smith AIA AICP
Survey Date: June 17, 2005

1. **Parking:** There were no designated accessible parking spaces.

Recommendation: At the nearest parking area to the entrance ramp, repair paved surface, configure accessible parking spaces, including 1 van-accessible space, with side access aisles, in accordance with the drawing below. Include upright signs at 5 feet high, with "van-accessible" sign.

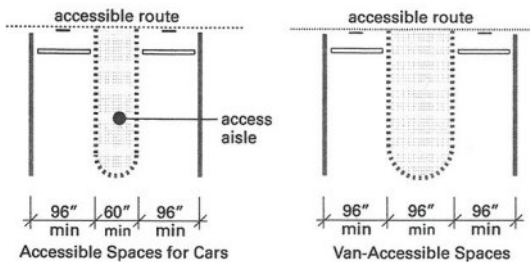

Gray Smith's Office

Architecture & Community Development
Expert Analysis & Testimony

Name of Polling Place: Delaware City Library & Community Center **County:** New Castle
FINDINGS AND RECOMMENDATIONS BASED ON ON-SITE SURVEY AND ADA REQUIREMENTS
Survey Performed by: Gray Smith AIA AICP
Survey Date: June 17, 2005

2. Route to entrance: The concrete walkway to the entrance ramp was characterized by several deep cracks.

Recommendation: Remove and repave the concrete walkway at 48 inches wide.

3. Entrance ramp: A wood entrance ramp was provided to the entrance; however, the handrails at the bottom did not extend beyond the end.

Recommendation: Supplement handrails to extend 12 inches similar to the drawing below.

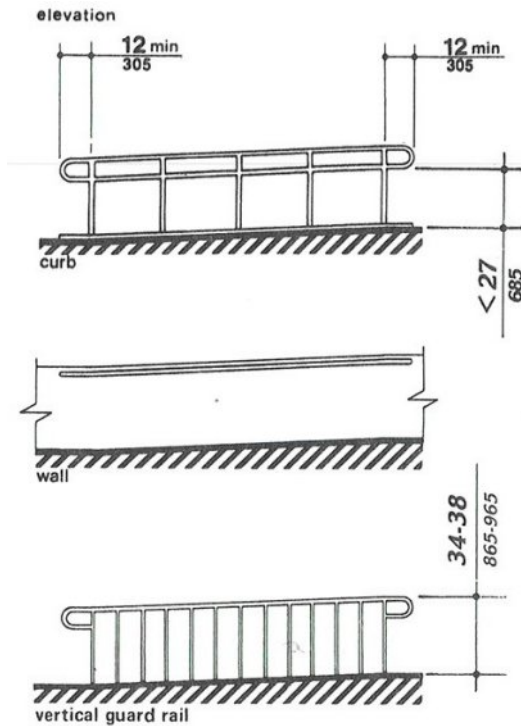

Gray Smith's Office

Architecture & Community Development
Expert Analysis & Testimony

DELAWARE COMMISSIONER OF ELECTIONS POLLING PLACE ACCESSIBILITY RECOMMENDATIONS	
Name of Polling Place: Westminster Presbyterian Church	County: New Castle
Address: 1502 W. 13 th Street, Wilmington	
Contact Person(s) Assisting Survey: Cara Hartsky	
Voting Area: Church: Community Hall & Rodney Chapel	

FINDINGS AND RECOMMENDATIONS BASED ON ON-SITE SURVEY AND ADA REQUIREMENTS

Survey Performed by: Gray Smith AIA AICP
Survey Date: June 24, 2005

Note: This facility contains 2 polling places.

- 1. Parking:** Accessible parking is provided; however, the surface paint is worn away and one van-accessible space has a faded "van-accessible" sign. The parking lot is across a street from the church building and the accessible spaces are a distance away from the 2 entrances.

Recommendation: On election day designate 2 on-street, accessible spaces near the entrances reserved for voters, with temporary signs. If possible, arrange with the local Department of Streets to make these 2 spaces permanent, with upright signs.



Gray Smith's Office

Architecture & Community Development
Expert Analysis & Testimony

Name of Polling Place: Westminster Presbyterian Church **County:** New Castle
FINDINGS AND RECOMMENDATIONS BASED ON ON-SITE SURVEY AND ADA REQUIREMENTS
Survey Performed by: Gray Smith AIA AICP
Survey Date: June 24, 2005

- 2. Rodney Chapel entrance:** Each of this pair of doors, when open, allows only 29 inches clear. The push pressure for these doors is 15 pounds to open.

Recommendation: Have personnel available on election day to hold open both doors in the pair for wheelchairs. Adjust or replace automatic door closers to assure a maximum of 5 pounds push pressure.

- 3. Entrance doors Community Hall and interior doors:** All of these pairs of doors require a push pressure of 12 to 15 pounds to open.



Recommendation: Adjust or replace automatic door closers to assure 5 pounds push pressure.



Gray Smith's Office

Architecture & Community Development
Expert Analysis & Testimony

DELAWARE COMMISSIONER OF ELECTIONS POLLING PLACE ACCESSIBILITY RECOMMENDATIONS	
Name of Polling Place: Luther Towers	County: New Castle
Address: 1201 N. Harrison, Wilmington	
Contact Person(s) Assisting Survey: Cara Hartsky	
Voting Area: Senior Apartments: Lounge	

FINDINGS AND RECOMMENDATIONS BASED ON ON-SITE SURVEY AND ADA REQUIREMENTS	
Survey Performed by: Gray Smith AIA AICP	
Survey Date: June 24, 2005	
<p>1. Parking: There is no on-site parking at this site, except for one “no parking” area on a rear sidewalk used on election day for disabled voter parking.</p> <p>Recommendation: Coordinate with local Department of Streets to designate 2, temporary accessible, on-street parking spaces near the building entrance. Install temporary signs. Do not use the rear “no parking” sidewalk location. If possible, make the 2 accessible spaces permanent in cooperation with the Department of Street, with upright signs.</p> <div style="text-align: center;">  </div>	 

Gray Smith's Office

Architecture & Community Development
Expert Analysis & Testimony

Name of Polling Place: Luther Towers **County:** New Castle

FINDINGS AND RECOMMENDATIONS BASED ON ON-SITE SURVEY AND ADA REQUIREMENTS

Survey Performed by: Gray Smith AIA AICP

Survey Date: June 24, 2005

- 2. Entrance ramp:** The concrete entrance ramp has a handrail on only one side on all 3 runs. The upper handrail is rectangular and does not have a graspable shape.

Recommendation: Install circular wall-mounted side handrails on other side of ramp and 2 circular wall-mounted handrails on the upper run of the ramp (replace rectangular handrail).



- 3. Entrance door threshold:** Metal threshold is loose and has raised above ½ inch (tripping hazard).

Recommendation: Replace with wider, beveled, low-profile, aluminum threshold.



Gray Smith's Office

Architecture & Community Development
Expert Analysis & Testimony

DELAWARE COMMISSIONER OF ELECTIONS POLLING PLACE ACCESSIBILITY RECOMMENDATIONS	
Name of Polling Place: Lincoln Apartments	County: New Castle
Address: 1625 Gilpin Avenue, Wilmington	
Contact Person(s) Assisting Survey: Cara Hartsky	
Voting Area: Senior Citizen Apartments: Community Room	

FINDINGS AND RECOMMENDATIONS BASED ON ON-SITE SURVEY AND ADA REQUIREMENTS

Survey Performed by: Gray Smith AIA AICP

Survey Date: June 24, 2005

- 1. Parking:** Accessible parking is provided; however, surface paint is worn away and van-accessible spaces do not have "van-accessible" signs.

Recommendation: Repaint surface and add "van-accessible" signs.

- 2. Entrance door:** The entrance door requires a push pressure of 20 pounds to open.

Recommendation: Adjust or replace automatic door closer to assure a maximum 5 pounds push pressure.



Gray Smith's Office

Architecture & Community Development
Expert Analysis & Testimony

DELAWARE COMMISSIONER OF ELECTIONS POLLING PLACE ACCESSIBILITY RECOMMENDATIONS	
Name of Polling Place: Immanuel Church, Highlands	County: New Castle
Address: 2400 W. 17 th Street, Wilmington	
Contact Person(s) Assisting Survey: Cara Hartsky	
Voting Area: Church: Community Room	

FINDINGS AND RECOMMENDATIONS BASED ON ON-SITE SURVEY AND ADA REQUIREMENTS

Survey Performed by: Gray Smith AIA AICP
Survey Date: June 24, 2005

- 1. Parking:** There is no on-site parking at the property. On-street accessible parking is marked with signs.

Recommendation: Coordinate with local Department of Streets to paint accessible spaces on street surface. Replace signs with that required by the DE Department of Transportation (see below).



Gray Smith's Office

Architecture & Community Development
Expert Analysis & Testimony

Name of Polling Place: Immanuel Church, Highlands **County:** New Castle
FINDINGS AND RECOMMENDATIONS BASED ON ON-SITE SURVEY AND ADA REQUIREMENTS
Survey Performed by: Gray Smith AIA AICP
Survey Date: June 24, 2005

- 2. Entrance ramp:** The exterior ramp to the polling place entrance ramps up to the door and has no handrails and there is an edge drop-off.

Recommendation: Remove and repave concrete ramp with a 5 feet deep, level landing at the door, and handrails with edge guards on both sides, as indicated in the drawing below.

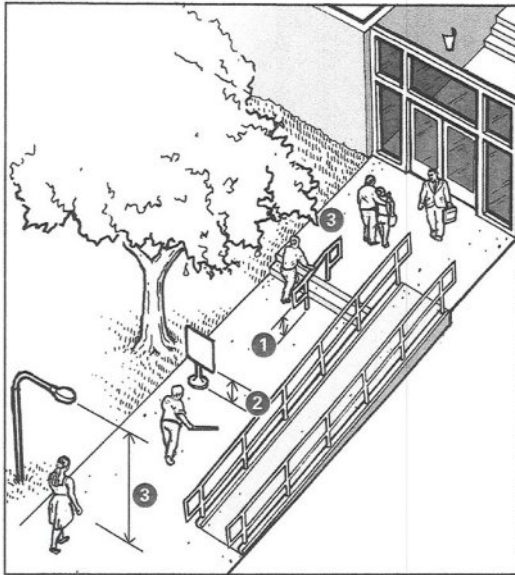

- 3. Entrance doors:** When open, each of the pair of doors allow only 30 inches clear in lieu of 32 inches.

Recommendation: On election day, have personnel available to hold open both doors for wheelchairs.

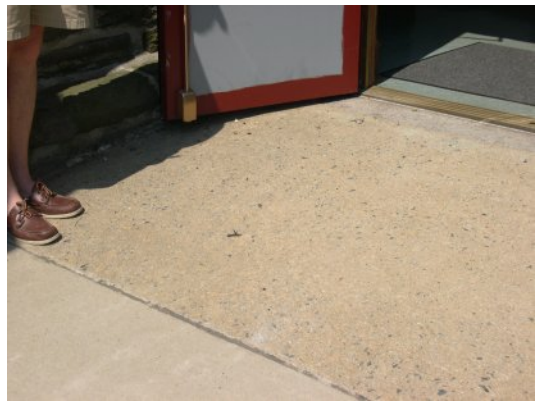

Gray Smith's Office

Architecture & Community Development
Expert Analysis & Testimony

DELAWARE COMMISSIONER OF ELECTIONS POLLING PLACE ACCESSIBILITY RECOMMENDATIONS	
Name of Polling Place: Tatnall School	County: New Castle
Address: 1501 Barley Mill Road, Wilmington	
Contact Person(s) Assisting Survey: Cara Hartsky	
Voting Area: Private School: Beekley Gymnasium	

FINDINGS AND RECOMMENDATIONS BASED ON ON-SITE SURVEY AND ADA REQUIREMENTS

Survey Performed by: Gray Smith AIA AICP
Survey Date: June 24, 2005

- 1. Parking:** No parking spaces are designated as accessible, although there is a large number of spaces.

Recommendation: Reconfigure and repaint sections of the parking lot nearest the (several) entrances, including that used for the polling place, in accordance with the drawing below. Include at least one van-accessible space and upright signs at 5 feet high, with a van-accessible sign. Install wheel stops to prevent vehicle contact with signs.

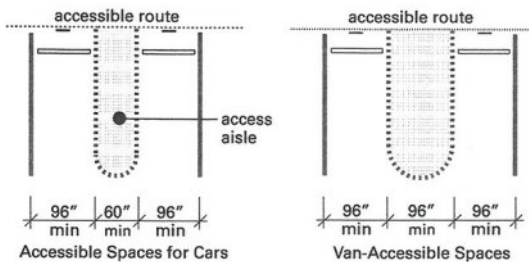

Gray Smith's Office

Architecture & Community Development
Expert Analysis & Testimony

Name of Polling Place: Tatnall School **County:** New Castle

FINDINGS AND RECOMMENDATIONS BASED ON ON-SITE SURVEY AND ADA REQUIREMENTS

Survey Performed by: Gray Smith AIA AICP

Survey Date: June 24, 2005

- 2. Curb ramp:** Edge of curb ramp is raised above $\frac{1}{2}$ inch at driveway. There is a cracked area of the flared side. There is no painted crosswalk on the adjacent driveway.

Recommendation: Cut out and build-up asphalt driveway surface to level with concrete curb ramp. Repair concrete flared side. Paint crosswalk for curb ramp to accessible parking spaces (see above). Also suggest "warning-crosswalk" signs both ways.

- 3. Entrance doors:** The entrance doors require 14 pounds push pressure to open. There is a raised concrete edge, higher than $\frac{1}{2}$ inch, at the threshold.

Recommendation: Adjust or replace automatic door closer to assure 5 pounds push pressure. Cut out and patch concrete with beveled epoxy cement.



Gray Smith's Office

Architecture & Community Development
Expert Analysis & Testimony

DELAWARE COMMISSIONER OF ELECTIONS POLLING PLACE ACCESSIBILITY RECOMMENDATIONS	
Name of Polling Place: Methodist Country House	County: New Castle
Address: 4830 Kennett Pike, Wilmington	
Contact Person(s) Assisting Survey: Cara Hartsky	
Voting Area: Retirement Community: Community Room	

FINDINGS AND RECOMMENDATIONS BASED ON ON-SITE SURVEY AND ADA REQUIREMENTS
Survey Performed by: Gray Smith AIA AICP
Survey Date: June 24, 2005

1. Parking: Accessible parking is provided; however, there is no van-accessible space, no upright signs, and the surface paint is worn away.

Recommendation: Reconfigure and repaint accessible spaces with side access aisles as indicated in the drawing below, and with one van-accessible space. Install upright signs at 5 feet high, with one "van-accessible" sign.

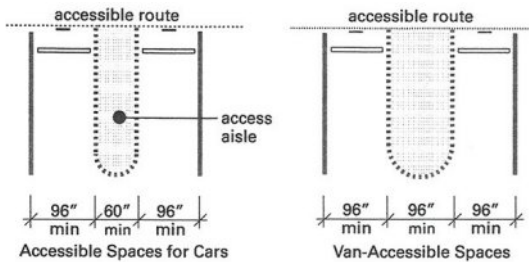

Gray Smith's Office

Architecture & Community Development
Expert Analysis & Testimony

DELAWARE COMMISSIONER OF ELECTIONS POLLING PLACE ACCESSIBILITY RECOMMENDATIONS	
Name of Polling Place: Lower Brandywine Presbyterian Church	County: New Castle
Address: 101 Old Kennett Road, Wilmington	
Contact Person(s) Assisting Survey: Cara Hartsky	
Voting Area: Church: Social Hall	

FINDINGS AND RECOMMENDATIONS BASED ON ON-SITE SURVEY AND ADA REQUIREMENTS
Survey Performed by: Gray Smith AIA AICP
Survey Date: June 24, 2005

1. Parking: Accessible parking spaces were provided; however, there was no designated van-accessible space and the surface paint was worn away. The parking spaces were somewhat sloped.

Recommendation: Reconfigure and repaint surface for accessible space, a van-accessible space, and side access aisles as indicated in the drawing below. Add a "van-accessible" sign. Replace upright signs with DE DOT approved signs.

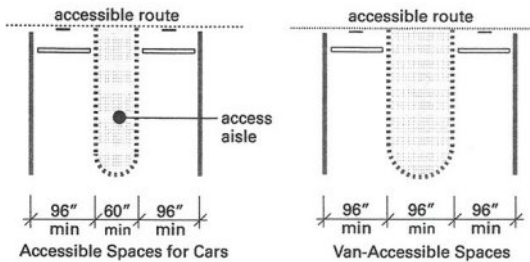

Gray Smith's Office

Architecture & Community Development
Expert Analysis & Testimony

Name of Polling Place: Lower Brandywine Presbyterian Church **County:** New Castle
FINDINGS AND RECOMMENDATIONS BASED ON ON-SITE SURVEY AND ADA REQUIREMENTS
Survey Performed by: Gray Smith AIA AICP
Survey Date: June 24, 2005

2. **Entrance:** There was a loose, curled edge mat at the exterior of the door.

Recommendation: Remove or replace mat with a smooth flat mat. Also remove "handicapped" and replace with universal symbol or "accessible".



Gray Smith's Office

Architecture & Community Development
Expert Analysis & Testimony

DELAWARE COMMISSIONER OF ELECTIONS POLLING PLACE ACCESSIBILITY RECOMMENDATIONS	
Name of Polling Place: St. Philip's Lutheran Church	County: New Castle
Address: 4501 Kirkwood Highway, Wilmington	
Contact Person(s) Assisting Survey: Cara Hartsky	
Voting Area: Church: Community Room	

FINDINGS AND RECOMMENDATIONS BASED ON ON-SITE SURVEY AND ADA REQUIREMENTS
Survey Performed by: Gray Smith AIA AICP
Survey Date: June 24, 2005

1. Parking: Accessible parking is provided; however, there are no designated side access aisles, no upright signs and no designated van-accessible spaces.

Recommendation: Install upright "van-accessible" signs at 5 feet high at the 2 accessible spaces and paint the intermediate surface and curb ramp as a wide side access aisle, similar to that indicated in the drawing below.

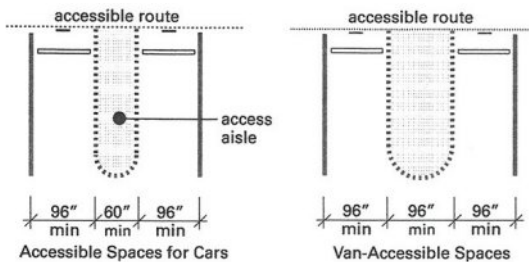

Gray Smith's Office

Architecture & Community Development
Expert Analysis & Testimony

Name of Polling Place: St. Philip's Lutheran Church **County:** New Castle

FINDINGS AND RECOMMENDATIONS BASED ON ON-SITE SURVEY AND ADA REQUIREMENTS

Survey Performed by: Gray Smith AIA AICP

Survey Date: June 24, 2005

- 2. Alternate entrance route:** Disabled voters enter through the Sanctuary entrance, directly in front of the accessible parking spaces. The built-up curb ramp; however, has a vertical edge at the concrete curb that exceeds $\frac{1}{2}$ inch.

Recommendation: Cut out asphalt \pm 6 inches at curb and add new asphalt patch to assure level transition onto curb.

- 3. Entrance doors:** When open, each of the doors in the pair provide only 27 inches clear rather than 32 inches. The push pressure of the doors is 20 pounds to open.

Recommendation: Provide personnel at doors to open both doors for wheelchairs. Adjust or replace automatic door closers to assure maximum of 5 pounds push pressure.



Gray Smith's Office

Architecture & Community Development
Expert Analysis & Testimony

DELAWARE COMMISSIONER OF ELECTIONS POLLING PLACE ACCESSIBILITY RECOMMENDATIONS	
Name of Polling Place: St. James Church Parish House	County: New Castle
Address: 2106 St. James Church Road, Wilmington	
Contact Person(s) Assisting Survey: Cara Hartsky	
Voting Area: Church: Parish House	

FINDINGS AND RECOMMENDATIONS BASED ON ON-SITE SURVEY AND ADA REQUIREMENTS

Survey Performed by: Gray Smith AIA AICP
Survey Date: June 24, 2005

Note: The entry to the interior of this facility was not available during this visit.

- 1. Parking:** Two wide accessible parking spaces are provided, however, the side access aisle is not between them. One upright sign is damaged and too low. Surface paint is worn.

Recommendation: Reconfigure and repaint the parking spaces, with a van-accessible space and an accessible side aisle, in accordance with the drawing below. Erect new upright signs at 5 feet high, with "van-accessible" sign.

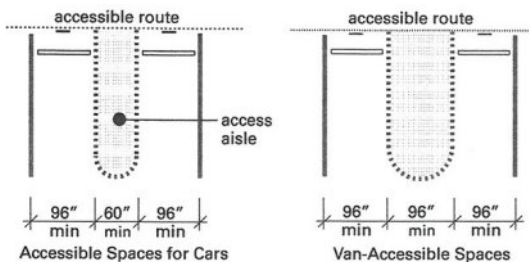

Gray Smith's Office

Architecture & Community Development
Expert Analysis & Testimony

Name of Polling Place: St. James Church Parish House **County:** New Castle
FINDINGS AND RECOMMENDATIONS BASED ON ON-SITE SURVEY AND ADA REQUIREMENTS
Survey Performed by: Gray Smith AIA AICP
Survey Date: June 24, 2005

2. Entrance ramp: The concrete entrance ramp has handrails that are 30 ½ inches high rather than 32 inches minimum. There is no edge protection to prevent slipping off. There are no extensions at the lower end of the railings. The bottom edge of the concrete ramp has a vertical rise greater than ½ inch at the driveway.

Recommendation: Replace the handrails with 2 new handrails in accordance with the drawings below.

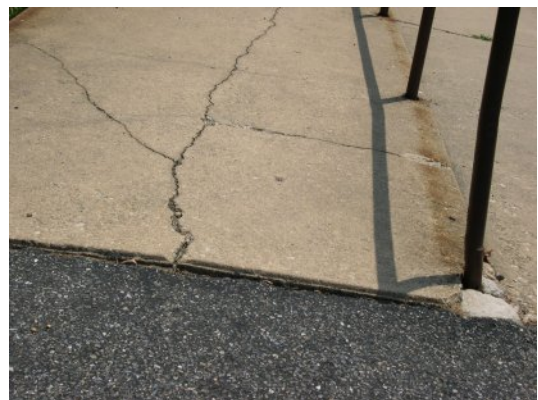
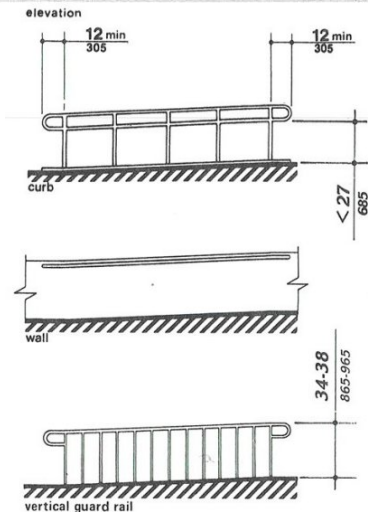
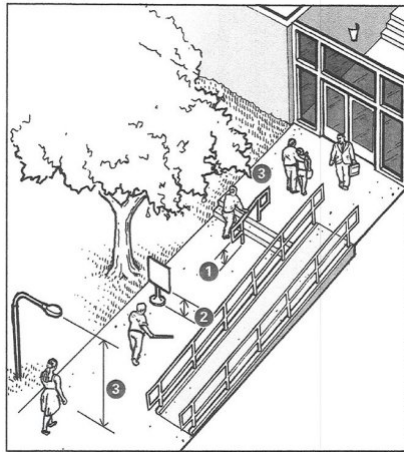

Gray Smith's Office

Architecture & Community Development
Expert Analysis & Testimony

DELAWARE COMMISSIONER OF ELECTIONS POLLING PLACE ACCESSIBILITY RECOMMENDATIONS	
Name of Polling Place: St. Catherine of Siena Church	County: New Castle
Address: 2501 Centerville Road, Wilmington	
Contact Person(s) Assisting Survey: Cara Hartsky	
Voting Area: Church: Lobby ("Gathering Space")	

FINDINGS AND RECOMMENDATIONS BASED ON ON-SITE SURVEY AND ADA REQUIREMENTS
Survey Performed by: Gray Smith AIA AICP
Survey Date: June 24, 2005

- 1. Parking:** In a large parking lot, 2 accessible spaces are provided; however, there were no side access aisles, no space marked as "van-accessible", no upright signs, and the surface paint was wearing away.

Recommendation: Reconfigure and repaint accessible parking to include side access aisles, and a van-accessible space in accordance with the drawing below. Add upright signs at 5 feet high, with one "van-accessible" sign. Install wheelstops to prevent vehicle contact with signs.

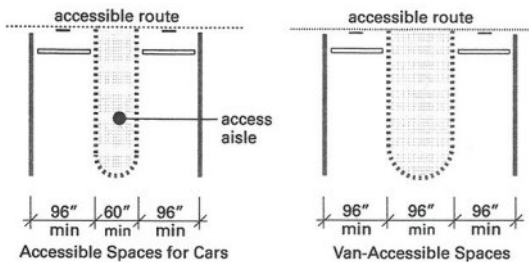

Gray Smith's Office

Architecture & Community Development
Expert Analysis & Testimony

Name of Polling Place: St. Catherine of Siena Church **County:** New Castle
FINDINGS AND RECOMMENDATIONS BASED ON ON-SITE SURVEY AND ADA REQUIREMENTS
Survey Performed by: Gray Smith AIA AICP
Survey Date: June 24, 2005

2. Entrance ramp: A concrete entrance ramp is provided; however, there is no handrail on one side, the one handrail does not extend to the full length of the bottom of the ramp, there is no edge protection to prevent slipping off.

Recommendation: Install 2 new handrails in accordance with the drawings below, with edge protection and extensions of 12 inches beyond the top and bottom of the ramp.

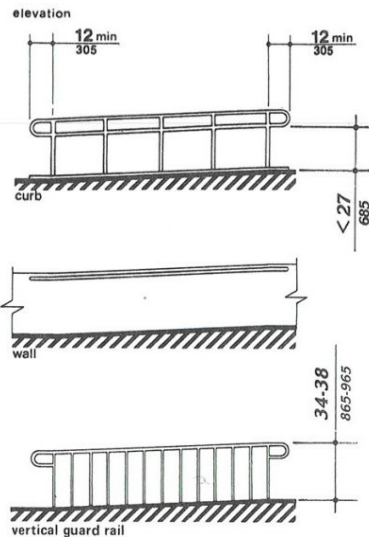
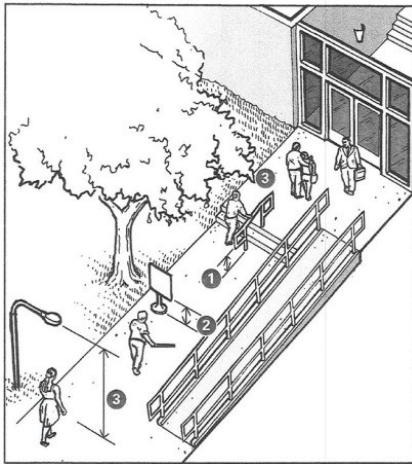

Gray Smith's Office

Architecture & Community Development
Expert Analysis & Testimony

Name of Polling Place: St. Catherine of Siena Church **County:** New Castle

FINDINGS AND RECOMMENDATIONS BASED ON ON-SITE SURVEY AND ADA REQUIREMENTS

Survey Performed by: Gray Smith AIA AICP

Survey Date: June 24, 2005

- 3. Entrance doors:** There is a thick entrance mat outside the door. The doors each require a push pressure of 15 pounds to open.

Recommendation: Replace the mat with a thin mat, or remove it on election day. Adjust or replace the automatic door closer to assure a maximum of 5 pounds push pressure.



Gray Smith's Office

Architecture & Community Development
Expert Analysis & Testimony

DELAWARE COMMISSIONER OF ELECTIONS POLLING PLACE ACCESSIBILITY RECOMMENDATIONS	
Name of Polling Place: Mill Creek Fire Company	County: New Castle
Address: 3800 Kirkwood Highway, Wilmington	
Contact Person(s) Assisting Survey: Cara Hartsky	
Voting Area: Volunteer Fire Hall: Banquet Hall	

FINDINGS AND RECOMMENDATIONS BASED ON ON-SITE SURVEY AND ADA REQUIREMENTS

Survey Performed by: Gray Smith AIA AICP

Survey Date: June 24, 2005

- Parking:** Accessible parking spaces are provided; however, there is no van-accessible parking space, and no upright signs.

Recommendation: Reconfigure and repaint accessible parking spaces to include a van-accessible space in accordance with the drawing below. Provide upright signs at 5 feet high, with a "van-accessible" sign.

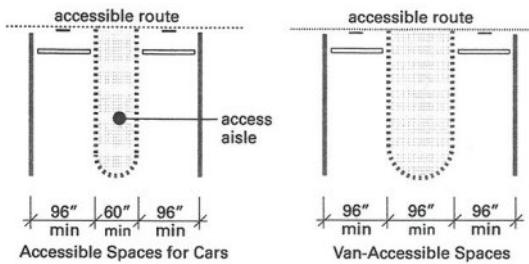

Gray Smith's Office

Architecture & Community Development
Expert Analysis & Testimony

Name of Polling Place: Mill Creek Fire Company **County:** New Castle

FINDINGS AND RECOMMENDATIONS BASED ON ON-SITE SURVEY AND ADA REQUIREMENTS

Survey Performed by: Gray Smith AIA AICP

Survey Date: June 24, 2005

- 2. Entrance ramp:** It was noted that the entrance ramp and handrails were in complete compliance with *ADA* accessibility guidelines.



- 3. Exterior and interior doors:** The exterior and interior doors required push pressure of 15 to 20 pounds to open.

Recommendation: Adjust or replace automatic door closers to assure maximum 5 pounds push pressure. In the alternative, keep the interior doors propped up on election day.



Gray Smith's Office

Architecture & Community Development
Expert Analysis & Testimony



DELAWARE COMMISSIONER OF ELECTIONS POLLING PLACE ACCESSIBILITY RECOMMENDATIONS	
Name of Polling Place: Manor Care Health Services	County: New Castle
Address: 5651 Limestone Road, Wilmington	
Contact Person(s) Assisting Survey: Cara Hartsky	
Voting Area: Nursing & Rehab Residence: Community Room	

FINDINGS AND RECOMMENDATIONS BASED ON ON-SITE SURVEY AND ADA REQUIREMENTS	
Survey Performed by: Gray Smith AIA AICP Survey Date: June 24, 2005	
<p>1. Parking: Although sized for van-accessible parking, there were no signs designating "van-accessible" spaces.</p> <p>Recommendation: Install "van-accessible" signs.</p>	

Gray Smith's Office

Architecture & Community Development
Expert Analysis & Testimony

DELAWARE COMMISSIONER OF ELECTIONS POLLING PLACE ACCESSIBILITY RECOMMENDATIONS	
Name of Polling Place: Limestone Presbyterian Church	County: New Castle
Address: 3201 Limestone Road, Wilmington	
Contact Person(s) Assisting Survey: Cara Hartsky	
Voting Area:	

FINDINGS AND RECOMMENDATIONS BASED ON ON-SITE SURVEY AND ADA REQUIREMENTS	
Survey Performed by: Gray Smith AIA AICP Survey Date: June 24, 2005	
<p>Note: Entry to the interior of this facility was not available during this visit.</p> <p>1. Parking: Accessible parking was provided; however, the surface paint was wearing away, and there were no upright signs.</p> <p>Recommendation: Repaint surface and install signs at 5 feet high, and designate a "van-accessible" space.</p> 	 
<p>2. Route to entrance: A cracked, bumpy hazardous condition was noted at the transition between the asphalt parking surface and the concrete walkway.</p> <p>Recommendation: Repair the area with concrete for a smooth transition.</p>	

Gray Smith's Office

Architecture & Community Development
Expert Analysis & Testimony

DELAWARE COMMISSIONER OF ELECTIONS POLLING PLACE ACCESSIBILITY RECOMMENDATIONS

Name of Polling Place: Mid-County Senior Center	County: New Castle
Address: First Regiment Road, Wilmington	
Contact Person(s) Assisting Survey: Cara Hartsky	
Voting Area: Senior Center: Multi-purpose Room	

FINDINGS AND RECOMMENDATIONS BASED ON ON-SITE SURVEY AND ADA REQUIREMENTS

Survey Performed by: Gray Smith AIA AICP

Survey Date: June 24, 2005

- 1. Parking:** Most of the accessible parking spaces are sized as van-accessible but not marked "van-accessible".

Recommendation: Install "van-accessible" signs.



- 2. Entrance ramp:** An entrance ramp is provided; however, the handrails are obstructed by a bench and flower pots, the handrails do not extend 12 inches at the bottom of the ramp, and there is no edge protection to prevent slipping off.

Recommendation: Replace handrails with railings in accordance with the drawings below with edge protection and extensions of 12 inches top and bottom. Remove bench and flower pots from ramp.



Gray Smith's Office

Architecture & Community Development
Expert Analysis & Testimony

Name of Polling Place: Mid-County Senior Center **County:** New Castle
FINDINGS AND RECOMMENDATIONS BASED ON ON-SITE SURVEY AND ADA REQUIREMENTS
Survey Performed by: Gray Smith AIA AICP
Survey Date: June 24, 2005

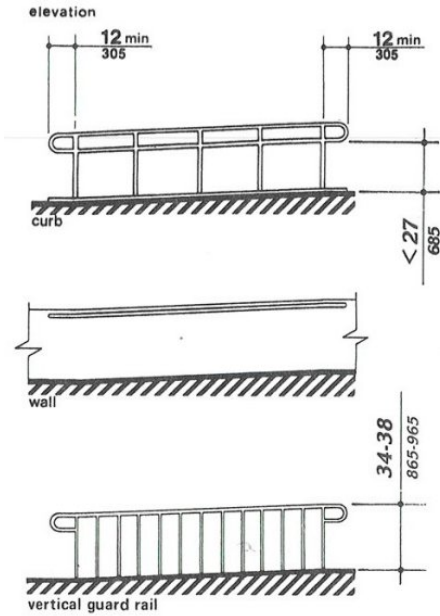

- 3. Entrance doors:** The entrance doors require a push pressure of 15 pounds to open.

Recommendation: Adjust or replace automatic door closers to assure a maximum of 5 pounds push pressure.

